

Mount Saint Vincent University
Department of Applied Human Nutrition

**Meals at the Home; Meals All Alone:
Nutritional Competency and Food Security Relative to Transition from
Residential Youth Care to Independence**

By
Valerie Blair

A thesis
submitted in partial fulfillment
of the requirements for the degree of
Master of Science in Applied Human Nutrition

October 2008
Halifax, Nova Scotia

©Valerie Blair

ACKNOWLEDGEMENT

The completion of this research study was made possible by the support of several people. I wish to express my gratitude to Dr Theresa Glanville who, as my Thesis Advisor, provided guidance, reassurance and support throughout the journey. I would also like to thank my Thesis Advisory Committee, Linda Wilson and Dr Michael Fitzgerald for their enthusiasm, and commitment to the youth care field.

I would especially like to thank my friends and family; Charlie, thank you for your encouragement and your faith in me at times when I did not. Finally, to my sweet, sweet Mary, in the wisdom a four-year-old, provided levity and perspective on matters of real importance.

DEDICATION

This thesis is dedicated to the many youth who have encountered challenging transitional journeys. To the youth care workers, thank you for your wisdom and your commitment to youth.

This thesis is especially dedicated to the youth who participated. Thank you for sharing your stories and demonstrating the true meaning of strength and resilience.

Abstract

Youth cared for as part of the child welfare system struggle with the transition from custodial care to independence. This has been attributed to a variety of reasons including lack of a social support network and limited financial resources. Residential group care facilities strive to guide youth towards autonomy and healthy adulthood by teaching independent life skills; however, these facilities vary in their emphasis and approach to life skills training and transitional support services. This research explored how youth in care develop nutrition competence, an issue of great importance given the relationship between dietary patterns and long-term health.

A naturalistic inquiry approach was used to better understand transition and the process of developing nutritional competence within the youth care environment. Seven youth and five residential youth care staff were purposively selected to participate. In-depth interviews were conducted using an interview script, the development of which was informed by Bronfenbrenner's Ecological Systems Theory. Data were analyzed using constant comparison methods that ultimately led to two major categories: Transitional Life Skills and Transitional Outcomes.

The development of nutritional competency was subject to many influences that were both internal and external to the residential group care environment. All the youth participants acknowledged nutritional competency development while residing in congregate care, however, the significant influences varied for each participant.

Transitional outcomes of homelessness, poverty and isolation impaired the youths' capacity to apply nutritional competencies. For many, transitional outcomes mediated

experiences of food insecurity and reliance on charitable organizations to supplement food intakes. Youth who had experienced unplanned discharges were more susceptible to homelessness, severe food insecurity and poverty. Conversely, the youth who followed a permanency plan that included residence in supervised apartments generally attained higher levels of education and had more comprehensive life skills.

Residential youth care staff identified nutritional competency development as an area that required more attention from various social influences including government stakeholders; youth care associations and community groups so that programs could do better in terms of preparing youth for transition.

The results of this study exposed some of the challenges youth face in the application of nutritional competency following transition from custodial care. A combination of incomplete life skills preparation and transitional adjustments to changes in social relations perpetuated the struggle. The establishment of supportive networks to bridge the gaps between the custodial care and independence environments will help improve the youths' transitional outcomes and capacity to utilize nutritional competencies. Transitional supports would include: family, youth care workers, social workers, adequate financial resources, supervised apartment placements and extensive life skill programs based on experiential learning

Table of Contents

CHAPTER I INTRODUCTION.....	9
1.1 Child Welfare Care System	9
1.2 Independent Living and Transitional Process	9
1.3 Purpose and Objectives.....	10
1.4 Significance.....	11
1.5 Glossary of Terms	12
CHAPTER II: LITERATURE REVIEW	13
2.1 Canadian Child Welfare System:	13
2.1.1 Children and Youth in Care:	14
2.1.2. Placement Options: Family-Based and Group Care Facilities:.....	14
2.1.3 Termination of Child Welfare Care Services	15
2.2 Transition and Change	16
2.2.1 Canadian Trends in Transitions to Independence:	18
2.3 Youth in Care Transitions.....	18
2.4 Common Transitional Outcomes and Nutritional Implications	19
2.4.1 Homelessness:	20
2.4.2 Lack of Life Skills:	20
2.5 Factors Related to Successful Transition.....	21
2.6 Independent Programming and Life Skills Training	22
2.7 Food Insecurity:.....	23
2.7.1 Determinants of Food Insecurity:	24
2.8 Poverty and Food Insecurity:	24
2.9 Transitioning Youth, Income Assistance and Food Insecurity:	25
2.10 Gaps in Transitional Support Services	27
CHAPTER III METHODOLOGY CONCEPTUALIZATION	28
3.1 Theoretical Paradigm: Constructivism	28
3.2 Theoretical Framework: Bronfenbrenner’s Ecological Systems Theory	28
3.2.1. The Microsystem	30
3.2.2 The Mesosystem.....	30
3.2.3 The Exosystem	30
3.2.4 The Macrosystem	31
3.3. Social Construction of Knowledge.....	32
3.4 Phase Theory.....	32
3.5 Researcher Identity.....	32
CHAPTER IV: METHODS	35
4.1 Naturalistic Inquiry as a Qualitative Approach.....	35
4.2 Sampling Procedure.....	35
4.2.1 Sample Size	36
4.3 Data Collection.....	36
4.3.1. Interviews	37
4.3.2 Field Notes	40
4.3.3 Household Food Security Survey Module	40
4.4 Data Analysis	41

4.5 Quality of Data.....	42
4.5.1. Credibility	42
4.5.2. Transferability	43
4.5.3 Dependability	44
4.6 Research Reflection.....	44
4.7 Ethical Considerations	45
CHAPTER V: RESULTS and DISCUSSION I: TRANSITIONAL LIFE SKILLS	47
5.1 Participant Demographic Characterization	47
5.2 Youth Care Facility Environment as an Influence	49
5.2.1 Portrayal of Residential Youth Care Facilities.....	49
5.2.2 Nutritional Competency Development within Youth Care Facilities.....	51
5.2.3. Limitations of the Youth Care Environment.....	53
5.2.4 Approaches to Nutritional Competency Programming	54
5.2.5 Youth Care Workers Role.....	60
5.2.6. Peers.....	65
5.2.7 Limitations of Time	66
5.3. Personal Influences to Nutritional Competency Development.....	67
5.4 External Influences on Nutritional Competency Development	70
5.4.1 Social Worker.....	71
5.4.2 Financial Restraints	72
5.4.3 Community Resources	73
5.4.4. School System	74
5.5. Social Influence on Nutritional Competency Development	75
5.6 Summary.....	76
CHAPTER VI: RESULTS and DISCUSSION II: TRANSITIONAL OUTCOMES	77
6.1 Introduction.....	77
6.2 Transitional Outcomes.....	77
6.2.1. Transitional Adjustment.....	79
6.2.2. Incomplete Life Skills.....	81
6.2.3. Isolation.....	83
6.2.4 Poverty	86
6.2.5. Homelessness	90
6.3 Food Insecurity and Transition	91
6.3.1 Food Bank Use and Transition.....	93
6.3.2 Approaches to Meet Nutritional Needs.....	94
6.4 Advice for Youth.....	98
6.5 Summary.....	99
CHAPTER 7: CONCLUSION and RECOMMENDATIONS.....	101
7.2 Limitations	108
7.3 Recommendations for Future Research:.....	108
7.4 Recommendations for Government.....	109
7.5 Recommendations for Academic Institutions:	110
7.7 Recommendations for Youth Care Workers.....	111
7.8 Recommendations for Transitioned Youth.....	112
REFERENCES	113
Appendix A.....	121

Recruitment Poster for Youth Participants.....	121
Appendix B.....	123
Letter to Youth Participants.....	123
Appendix C.....	126
Letter to Youth Care Facility Participants.....	126
Appendix D.....	129
Interview Script for Youth Participants	129
Appendix E.....	132
Interview Script for Youth Care Facility Representatives	132
Appendix F.....	135
Household Food Security Survey Module	135
Appendix G.....	140
Free and Informed Consent for Youth Participants	140
Appendix H.....	143
Free and Informed Consent for Youth Care Facility Representatives	143
Appendix I.....	146
Consent to Voice Recording.....	146

Table of Figures

Figure 1: Bronfenbrenner’s Ecological Systems Theory Model.....	29
Figure 2 Custodial Care Influences.....	48
Figure 3 Transitional Outcomes	78
Figure 4: Custodial Care Influences Model.....	102
Figure 5: Transitional Outcomes Model	106
Table 1: Demographic Profile of Youth Participants.....	148
Table 2: Demographic Profile of Youth Care Facilities	150
Table 3: Sample of Coding	152

CHAPTER I INTRODUCTION

1.1 Child Welfare Care System

In an ideal world, a child lives with their family and gradually transitions to independence as s/he matures. However, many children leave their home environment at an early age because of unsafe conditions, typically neglect or abuse. While the effects of family dissolution are widespread and not easily understood, this separation can precipitate a legacy of victimization, distrust, uncertainty and a lack of self-efficacy. Following removal from their home, many children and youth will live in government sponsored community-based group care facilities including group homes and foster families. Some youth present with complex issues resulting in multiple transitions as the child welfare care system struggles to find suitable placements to meet the young persons' individual needs.

Youth in care in Nova Scotia can remain in out-of-home placements until they 'age out' of the system at 18. Depending on individual circumstance, support may be extended to age 21 or the young person may leave prematurely as early as age 16. (1) Given that young adults in stable family systems delay transition from the home until their mid twenties (2), youth leaving at such an early age may be less prepared for assuming autonomy.

1.2 Independent Living and Transitional Process

The process of preparing for transition from a community-based group care setting to independent living is typically achieved through a collaborative effort involving the young person, the social worker and the youth care team. Presently, the Nova Scotia child welfare system does not have a standardized independent life skills training program; therefore, programs are individualized based on the young person's perceived needs.

A common focus of the youth care team is to teach various life skills considered vital to successful transition to independent living. Food related skills, knowledge and awareness, as summarized in the phrase ‘nutritional competency’, are believed to be a significant component of any life skills program. Despite the value of nutritional competence, there is little known about how it is achieved within this setting. This study will seek to gain an understanding of the process of becoming nutritionally competent within the youth care facility environment and the value placed on these competencies once independence is achieved. This study will also explore the impact of nutritional competency on food security.

1.3 Purpose and Objectives

The purpose of this research was to gain a better understanding of nutritional competency (skills, knowledge and awareness) and the consequent impact on food security of former youth in care. By extension, this exploration identified social constructs that impact the food related experiences of the youth. This allowed for the identification of service and program gaps that affect the youth, their nutritional competencies and their food security. Consistent with this, the specific objectives of this research were:

1. To gain an understanding of the process of independence transition from a residential youth care facility as experienced by former ‘youth in care’, in terms of nutritional competencies (skills, knowledge, awareness) and food security;
2. To gain an understanding of the effectiveness of independent life skills programming, emphasizing nutritional competencies, as delivered in residential youth care facilities following transition to an independent living environment;

3. To identify potential changes in practice and delivery of independent life skills programs that might improve the nutritional competencies and social functioning of former youth in care; and
4. To identify the social constructs that impact the youths' nutritional competencies and food related experiences, pre and post discharge from a youth care facility.

1.4 Significance

This research will contribute to the current understanding of the transitional process for youth residing in community- independent living environments. Moreover, youth transitions will be considered in relation to the impact on nutritional competence and food insecurity. The conclusions drawn from the study will help inform programs practices and policies that impact the youths' nutritional competence in order that gaps in service may be addressed.

1.5 Glossary of Terms

A&A-FC	Agriculture and Agri-Foods Canada
CCCM	Children in Care and Custody Manual
CCHS	Canadian Community Health Survey
CCSD	Canadian Council on Social Development
CCWL/LBEC	Child Welfare League of Canada/ Ligue pour le bien-être de l'enfance du Canada
CNHA	Canadian Nutrition and Health Atlas
DC	Dietitians of Canada
ESIA	Employment Support and Income Assistance
HFSSM	Household Food Security Survey Module
NCW	National Council of Welfare
NSDCS	Nova Scotia Department of Community Services
NSF&CSA	Nova Scotia Family and Children's Services Act
NSPFSP	Nova Scotia Participatory Food Security Projects.
NYCN	National Youth in Care Network
YCF	Youth Care Facility

CHAPTER II: LITERATURE REVIEW

This chapter will begin with a brief exploration of the Canadian Child Welfare System including an introduction to the experience of being a ‘youth in care’ and the services currently used within the system, such as placement options, programming and transitional supports. Following this, the transitional paradigm will be contextualized through the process, and the impact of youth ‘aging out’ of the child welfare system on nutritional competency. The chapter will conclude with an exploration of relationship between poverty and food security and the management strategies employed to address food security issues

2.1 Canadian Child Welfare System:

In Canada, provincial and territorial governments have legislative responsibility to provide services for children who are abused, abandoned or neglected by their parents and deemed “in need of protection”. One notable exception is the federal government responsibility of First Nations peoples. When a child is determined “in need of protection”, the government assumes responsibility either on a temporary or permanent basis; this is referred to as “taking a child into care.” (3)

The definition of ‘child’ varies across provinces and territories. (4) In Nova Scotia, a child is defined as “a person under 16 years of age unless the context otherwise requires.” (1). This means that the Province of Nova Scotia is only obligated to provide protective intervention services to children until age 16 in contrast to other provincial/territorial jurisdictions where services are provided to age 18 or 19. (5) The autonomy of provincial and territorial child welfare legislation makes it difficult to compare services and there has been little effort to gather the necessary information. (4) Nonetheless, it is reasonable to propose that early discharge of youth from care will be associated with a lower level of preparedness.

2.1.1 Children and Youth in Care:

The number of children and youth in care in Canada is estimated to be approximately 80,000, representing a 60% increase over the past 5 years. (6) The 1999 Child Welfare in Canada Report (7) indicated that 1906 children are in custodial care in Nova Scotia; 58% living in family-based care and the remainder being served through group care and institutional/residential treatment facilities.

Children and youth who enter 'care' often have "developmental, emotional, behavioral and health problems reflective of the difficult family and environmental circumstances that caused them to be removed from their homes in the first place," suggesting that they are a vulnerable population. (8) The adversity of these childhood experiences can precipitate a legacy of victimization and maladaptive coping behavior resulting in poor educational outcomes, low employability, substance use disorders and homelessness. (9-14)

2.1.2. Placement Options: Family-Based and Group Care Facilities:

Practices within the child welfare system have been shaped by ideological movements. The current trend favours family preservation wherein child welfare care professionals intervene to diffuse situations and resolve problems so that the child can stay in the family unit. (15) When this approach fails, the child will be removed from the home and placed in either family-based or group-based care. The choice of placement in custodial care in Nova Scotia is guided by a comprehensive review of the child's needs and available resources. The goal is to provide a placement that best suits the child's needs but this is not always possible (16)

Family-based foster care is the preferred placement option (4) Youth in therapeutic foster care demonstrate "better adjustment at follow-up in terms of post-discharge stability of living situation than youth served in congregate care settings."(4) Typically, family-based placements

can offer a degree of continuity, commitment and individualized care, typical of stable, family oriented environments. In comparison to community based residential facilities, youth residing in family based care are more likely to have fewer school changes, stability within the immediate living environment, and consistency in routine, all of which contribute to the development of essential life skills.

In contrast to the family based foster care, group care facilities are “artificial” (institutional) in that they attempt to create a family environment when one does not naturally exist. (15) These facilities are “purpose-built”, to help the young person have “transitional” and “approximating” experiences that will act as bridges back to full participation with family and/or community life. (17) As such, the group care setting strives to create a “sense of normality” in terms of teaching socially acceptable behavior, establishing household routines, recognizing developmental needs of the children and youth, and by offering programs, services and life skills instruction. However, by their very nature, these facilities function by group norms and routines that are contraindicative to trial and error learning based on individual needs. As reported in one study, “in congregate placements young people are less likely to gain practical experience in tangible life skills such as decision making, time management, seeking and holding employment, shopping or assuming financial responsibility for paying bills on a regular basis.” (18)

2.1.3 Termination of Child Welfare Care Services

An 18th birthday is a significant milestone in that it marks the legal passage from childhood to adulthood. This birthday for youth in care takes on the added significance of being the age when protective services are terminated. At this age, the youth is no longer a “child in need of protection”, but is considered an adult with all the associated responsibilities. (19) This is

referred to as ‘aging out’ of the system. In the case of a premature departure, initiated by either the youth or the Province, this event can occur as early as 16 years of age. (1)

Regardless of the circumstances surrounding discharge, youth leaving the Child Welfare System often face a plethora of challenges as they experience the transition to adulthood and independent living. Transitional change, in tandem with compromised support systems; limited financial resources and inadequate independence/life skills training contribute a number of undesirable outcomes. Compared to their peers, youth ‘aging out’ of the Child Welfare Care are more likely to drop out of school, become a young parent, be dependent on social assistance, experience food insecurity, be unemployed or underemployed, experience homelessness, and be at higher risk for substance abuse problems. (3,12,14)

2.2 Transition and Change

Transitional periods are characterized by the uncertainties individuals face in the adjustment to new and unfamiliar developmental challenges. Change and transition is “journey into the unknown, different for every individual and organization.” (20) One author suggests that “change is the basis of both growth and destruction and thus can be either a resource or a problem, depending upon the impact it has on the individual and on the rest of the system.” (21) The polarity of growth and destruction complicates our understanding of transition; what is gained and what is lost is highly subjective, influenced by the diversity of individual life experience and circumstance. One assumption that complicates the understanding of transition is the tendency for people to impose personal experience onto others - if I can do it then you should be able to as well. This generalization is problematic for children ‘in care’ in that childhood experiences of family dissolution leave them ill equipped to face transitions that are neither planned nor desired. (21)

The transition from adolescent to adulthood is one where relationships with parents, family, peers, schools and community institutions are redefined, modified or terminated. It is also marked by the matters associated with independent living such as decision-making, personal relationships, career direction and the acquisition of knowledge and skills conducive to self-sufficiency and independence. (22) In essence, this transition stage is marked by an unsettling of the status quo. Hartman and Zimberoff, as cited in Smart state, “Humans in general prefer consistency and status quo to instability and therefore when change inevitably comes they attempt to avoid the transition between the status quo and whatever comes next.” (21) The avoidance can come in many forms of indecision, ambivalence and procrastination. (20) As an example, youth in custodial care, youth living independently and youth in transition apartments were asked to share feelings on transition, those currently ‘in care’ and anticipating discharge appeared to be most in crisis. This group expressed the most anxiety and greater ambivalence about being on their own. (23) Although the cause is unclear, it is likely that these feelings were rooted in a history of difficult transitions and a real or perceived lack of readiness in terms of life skills and support networks.

Transition and change are inherently different concepts even though they are often used interchangeably. This difference needs to be recognized if practitioners are to become transitionally aware. (21) Winfield states that “change refers to the situational: the new boss, the new site, the new team rules or the new policy” whereas transition is a psychological process people experience in response to a new situation. Using this definition, change is external while transition is internal.” (24) Conceptualizing transition as an internal phenomenon is key to understanding the complexity of the process for youth in care, as it requires “consideration of how individuals make sense of their world and give meaning to the shaping of their experiences of it.” (20)

2.2.1 Canadian Trends in Transitions to Independence:

A recent comparison of 1971 and 2001 Canadian census data shows that the transition to adulthood in 2001 was “delayed and elongated” compared to that in 1971. (2) Young adults are staying longer in their family home, leaving school later and consequently delaying entry into the labour market. In essence, young people are taking longer to reach independence, which speaks to the inherent complexity of transition. Paraphrasing Reid and Dudding, an accepted occurrence for young people today is that “when the going gets tough, the tough move back in with Mom.”(19) This alternative is not readily available for many former youth ‘in care’ who are expected to navigate transition with little or no support.

2.3 Youth in Care Transitions

“ We come into the lives of young people with the goal of helping them leave us.” (25)

~ Mann-Feder &Garfat

The age of transition is a key factor in framing difficulties experienced by youth in care. The decision to discharge the youth is based on age rather than ability. Self-sufficiency is expected regardless of the individual’s state of readiness, emotionally, developmentally or financially. The ending is abrupt and always final leaving little room for mistakes and failures. Further complicating the situation is the emotional vulnerability of the population. For youth in custodial care, the meaning associated with transition is not usually hopeful. Often it is rooted in traumatic experience such as being ‘removed’ from the family home thereby transition to independence can “stimulate memories of initial placement experiences and rekindle rage and confusion.” (26) Garfat in discussing construction of meaning states, “the way we make meaning of experiences very much influences, and perhaps even determines, how we respond to them.”

(27) Childhood memories of negative transitional experiences can create associations of pain and hurt with leaving that in turn impact their transitional journey.

Youth-in-care need support for the transition to independence. Some promising suggestions to ease the transition from care include an extension of the maximum age to receive support; establishment of a safety net comprised of community resources; establishment of after-care support services such as extended health benefits and education opportunities; and standards to guide independent life skills programming. (3, 11, 19) Further suggestions, as presented by concerned youth included a need for on-going support past the age of majority; the establishment of a peer mentoring service; semi/supported independent-living housing, after-care programs accessible to all youth leaving care; improved financial resources and enhanced transitional-skill training to begin before 'in care' and extend beyond the age of majority. (28)

2.4 Common Transitional Outcomes and Nutritional Implications

Youth in care will have different experiences, many of which are heartbreaking, as they transition to successful independent living. Solutions to the issues they face remain elusive. Little is known about the nutritional implications of poor transitional life skills preparation. However, it is known that common transitional outcomes encountered by former youth in care, such as homelessness, isolation, and poverty, are potential indicators of compromised nutritional status. (10, 14, 29-31) A single study looking at nutritional status of youth in transition reported that one quarter of the sample (n=603) was classified as food insecure based on a composite measure of food security. (14)

2.4.1 Homelessness:

A disconcerting number of former youth-in-care become homeless at some stage. (9-11, 32, 33) The National Survey of Homeless Assistance Providers and Clients observed that approximately 40% of homeless adults aged 18 to 20 years were in the foster care system as youth. (34) A client profile of a Toronto outreach center reported that 47.5% of street youth seeking services were former 'youth in care' (35)

Periods of homelessness can have serious nutritional implications (31) as limited economic and social resources force individuals to prioritize their needs and work within the limitations of their environment. As such, charitable organizations, such as food banks, supper churches and soup kitchens become the primary food sources. Due to the donor-reliant nature of these programs, the nutritional value of the food distribution is the product of what is available rather than what is needed. Consistent with this, a study of homeless youth in Toronto reported that over half had inadequate intakes of folate, vitamin A, vitamin C, magnesium and zinc; additionally, more than half of the female respondents had inadequate dietary intakes of vitamin B-12 and iron. (36)

2.4.2 Lack of Life Skills:

Education on basic life skills through structured programming, observation and experiential learning is one method of preparation for independence. The usefulness of life skills training is often unknown until the youth is actually living on their own, which is beyond the time when effective changes to programming can be made. Courtney, et al reported that 77% of the youth surveyed felt prepared in terms of life skills training prior to discharge but this decreased to 29% once they had transitioned to independent living. (10) This illuminates the gap

between life skills training and actual practice due in part to a lack of experiential learning opportunities. (28)

The disconnect between life skills preparation and actual practice is supported by a study which showed that while 65% of the youth had received “food management” services, only 28% had pots and pans to set up a household. (11) This clearly points to a lack of congruence between the life skills training and the practicality of skill execution. The inability of life skills programs to adequately prepare the youth for independence can have a negative impact on nutritional status.

2.5 Factors Related to Successful Transition

Factors key to a successful post child welfare care transition include: education, housing, relationships, life skills, identity, youth engagement, emotional healing and financial support. (3, 6, 19, 28) In an effort to improve transitional outcomes, youth participants in one study made the following recommendations: move toward a youth focused practice, more collaboration and better communication with youth, and facilitation of permanent connections. (28) Clearly, the youth were asking for more time, more support, increased decision making power, and a chance to practice skills and make mistakes with the security that there are supports to rely on when and if needed.

Some advocates for youth in care support a fundamental shift in transition ideology from that of independence to inter-dependence. (19) The concept of inter-dependency speaks to an individual’s ability to meet her or his “physical, cultural, social, spiritual, economic and emotional needs within the context of relationships with family, friends, employers and community.” (19) The need for on-going support in the form of family or community involvement has been shown to increase the chances of a successful transition from the child

welfare system (12) and yet, the custodial care system does not always facilitate the nurturance of these relationships. (37) Family and community connections help bridge the gap between the child welfare system and independence through the provision of a continuous support of a significant other(s).

The provision of transitional and post-discharge supports has been overshadowed by the current emphasis placed on prevention, which typically involve younger children. As presented by Collins (12), a narrow focus on preventive interventions can explain the lack of attention given to adolescents in the child welfare system. While there is acknowledgement that youth in transition to independence require additional supports, there is little guidance as to best practices to accomplish this outcome. A lack of appropriate transitional support for youth in care can impact many areas of their lives including ability to secure stable living arrangements, access to education and adequate nutrition. The transition from a youth care facility with its inherent benefits in terms of food security, to an independent living arrangement is a challenge for many young people.

2.6 Independent Programming and Life Skills Training

Approaches to life skills development and transitional preparation vary. In Nova Scotia, transitional life skill preparation is the responsibility of the social worker and typically involves consultation with the youth's caregivers. (16, 19) Although placement agencies at the Provincial level have invested in transitional programs and interventions, a comprehensive, federally funded program is lacking. As such, the transitional preparation programs differ from Province to Province and Agency to Agency in response to budgets, interest, value judgments, available resources, skills and knowledge. The development of a National Independent Living Program would create a unified program to ensure the opportunity for all youth in custodial care to learn

necessary transitional life skills. The United States supports a National Independent Living Program that has been credited for improving transitional outcomes of youth in custodial care. (10, 11, 38-40)

The failure of transitional life skills programs to adequately prepare youth for transition is well documented. In interviews conducted by the Victoria Youth in Care Network in 1997, youth felt they lacked “ a variety of everyday healthy living skills; they wished that they had the time and opportunities to practice these skills in order to be better prepared to live on their own.” (28) A recent poll asking if youth are prepared to leave care indicated that 47% have ‘not received any preparation’, 32% are ‘not sure/trying’ and 21% are ‘ready’. (41)

The emphasis on life skills training can differ between males and females. In a study examining the preparedness for independent living, female respondents were more likely to report that they received an in-depth education and employment program whereas male respondents reported exposure to just one component of the same program. Additionally, female respondents were more likely to receive health education such as nutrition, first-aid, family planning and birth control. (14) The existence of a gender differential and the impact on programming warrants further investigation.

2.7 Food Insecurity:

The concept of food security is a complicated, multifaceted issue that is subject to multiple perspectives affecting all levels of the social strata, from the individual to the universal. As defined at the 1996 World Food Summit, “food security exists when all people, at all times, have physical and economic access to sufficient, safe and nutritious food to meet their dietary needs and food preferences for an active and healthy life.” (29) The 2004 Canadian Community Health Survey reports that 9.2% of Canadians are food insecure with 2.9 % reporting severe food

insecurity and hunger. (42) Nova Scotia has the highest rate of food insecurity with 14.6% reporting some degree of food insecurity. (42) The reasons for this are unknown but may relate to social welfare policies.

2.7.1 Determinants of Food Insecurity:

The presence of food insecurity is mediated by multiple factors that differ from person to person and household to household. Perhaps the most prominent determinant is inadequate monetary resources. Many people are at risk of experiencing food insecurity, however those relying on social programs like income assistance are most vulnerable. Recent data indicate that 59.7% of households supported by social assistance incomes experienced food insecurity within the previous 12 months. (42) Other contributors include a lack of knowledge and skills, a shortage of time, isolation and inadequate cooking facilities and equipment.

2.8 Poverty and Food Insecurity:

Poverty in Canada is defined using Statistics Canada pre-tax low-income cut offs (LICO's). Low-income cut offs are "meant to convey the income level or threshold at which a family may be experiencing difficulties because it has to spend a greater portion of its income on the basics (food, clothing and shelter) relative to the average family of similar size." (43) People living on incomes that fall below this low-income cut-off would be considered living in poverty.

The issue of poverty and its effects on nutritional health has been widely studied in Canada. A study of welfare recipients living in Toronto found that regardless of whether rental arrangement was rent-geared-to-income or market value, the welfare income of single person households could not meet basic needs and consume a healthy diet. (44) Households reporting food insecurity are also likely to report other health problems such as heart disease and major

depression. (45) A similar relationship between food insecurity and poor health was observed in homeless youth living in Toronto. (36) This study is of direct relevance to the issue of youth in care transitioning to independent living situations because they are at greater risk of homelessness as a direct result of their lack of life skills, supports and financial resources

2.9 Transitioning Youth, Income Assistance and Food Insecurity:

“I was given information about the nearest welfare office. That’s about it.”

Former Youth in Care

Arguably, discharge from the child welfare system is often synonymous with a “graduation” to income assistance, simply because the young person is not adequately prepared to do much else, as early transitions can place individuals “out of sequence with prevailing institutional structures” (12). As evidenced in the research literature, a high percentage of youth in care do not reach key milestones such as completing school and securing stable employment. (3, 11, 12, 19, 28) This lack of employability secondary to below average educational achievement leads to a greater reliance on social assistance programs for support.

The issue of poverty and by extension food insecurity is not the result of a lack of food but rather the “gross inequalities of income and the even more unequal distribution of wealth and the fact that the persistence of inequality of income and wealth is assisted by government policy.” (46) As a result, food insecurity is more prevalent in households in which the main source of income is social assistance (59.7%) with these households reporting both severe (30.2%) and moderate (29.6%) food insecurity.” (42) In Nova Scotia, a single employable person on income assistance receives an annual income of \$5,422, which amounts to 30% of the \$17,895 poverty line and translates into a ‘poverty gap’ of \$12,473. (45) The impact of the

poverty gap on food insecurity was demonstrated by the 2007 Nova Scotia Participatory Food Security Project (47) wherein it was estimated that a lone male age 30 on income assistance would have a monthly deficit of \$217.39 if a nutritious food basket were purchased in addition to fixed costs for shelter and other basic expenses. An alternative scenario considering a single male working 40 hours per week at a minimum wage of \$7.15/hour, determined that after purchase of a nutritious food basket the individual would have \$109.39 to cover all other expenses such as recreation, personal hygiene, prescriptions, etc. (48)

While issues of social policy and market forces are largely beyond the control of those experiencing food insecurity, individuals cope by adopting strategies to meet their nutrition needs. Some of the management strategies identified in the literature include household activities such as cooking large batches of food; spreading or stretching meals out over several days; and changing food appearance to avoid monotony. (30) Further, strategies to manage food insecurity include, not paying or partially paying monthly bills (49-50); and substituting nutritious high quality food for a less expensive, less nutritious option. (49, 51)

The reliance on family and friends has been identified as a strategy to address food insecurity; specifically, this entails support in the form of food and money. (49, 52) In terms of youth leaving child welfare care, the reliance on family for food and money may be particularly challenging because the custodial care arrangement may contribute to the erosion of family ties and relations. (37)

Participation in charitable and/or voluntary organizations, such as food banks to cope with food insecurity is another prominent strategy to address food insecurity. The use of a food bank was a clear marker for food insecurity, in that “90% of households had incomes which were less than two third of the poverty line and the majority of households were supported either in whole or part by social assistance programs.” (53)

Specific to former youth in care, the strategies to address food insecurity may be more challenging to employ if they have not been adequately prepared for independence. Often the youth do not have contact with their family and their peers are frequently living in similar difficult circumstances. It would seem that skills and knowledge to budget creatively, grocery shop prudently, communicate effectively in order to determine available resources and plan in advance are all fundamental to the successful prevention of food insecurity.

2.10 Gaps in Transitional Support Services

Within residential group care, a common approach to transitional planning includes the development of nutritional competency. Yet, there have not been any studies assessing the usefulness of this knowledge when applied to an independent living situation. Do the youth care facilities adequately prepare young people for independent living? What are the barriers to the development of food related skills and nutrition knowledge within congregate care facilities? Could occurrence of food insecurity experienced by recently transitioned youth be reduced through adequate training programs and services? These questions will emerge throughout this study exploring the effectiveness of nutritional competency development within residential youth care facilities in the Nova Scotia Central Region.

CHAPTER III METHODOLOGY CONCEPTUALIZATION

3.1 Theoretical Paradigm: Constructivism

This study was guided by a constructivist theoretical paradigm, which holds that knowledge and truth are not just found in the world and, most important, are not absolute and independent of human experience. (54) The philosophy of constructivism acknowledges that diversity of experience and perception will exist among the participants. The different perspectives can be examined as “multiple realities” without attempting to pronounce which set of perceptions is ‘right’ or more ‘true’ or more ‘real’. (55)

3.2 Theoretical Framework: Bronfenbrenner’s Ecological Systems Theory

Bronfenbrenner’s Ecological Systems Theory (56) complements the constructivist paradigm because of its ecological orientation; “what matters for behavior and development is the environment, as it is ‘perceived’ rather than, as it may exist in ‘objective’ reality.” (56) This theory also provides a blueprint for the identification of various ecological facets such as social, political, economic, and gender differentials that impact an individual’s constructed reality.

This framework is particularly useful in discussing the transitional process and nutritional competency in its emphasis of the various strata of influence on a particular phenomena or experience. (Figure 1) The theory inherently exhibits the impacts within and between social relations; in turn demonstrating the complexity of an individual’s social construction. The framework by virtue of fluidity would suggest that solutions to challenges faced by youth in care and those that work with them, cannot be restricted to just one socio-ecological system rather genuine sustainable solutions require supportive interventions on all levels. The use of this theory will help illuminate the shift in social relations that mark transition from custodial care to

independence. The ecological systems framework, as used in this study is represented below. For this purpose, the example will be a former youth in care.

ECOLOGICAL SYSTEMS THEORY MODEL (Bronfenbrenner, 1979)

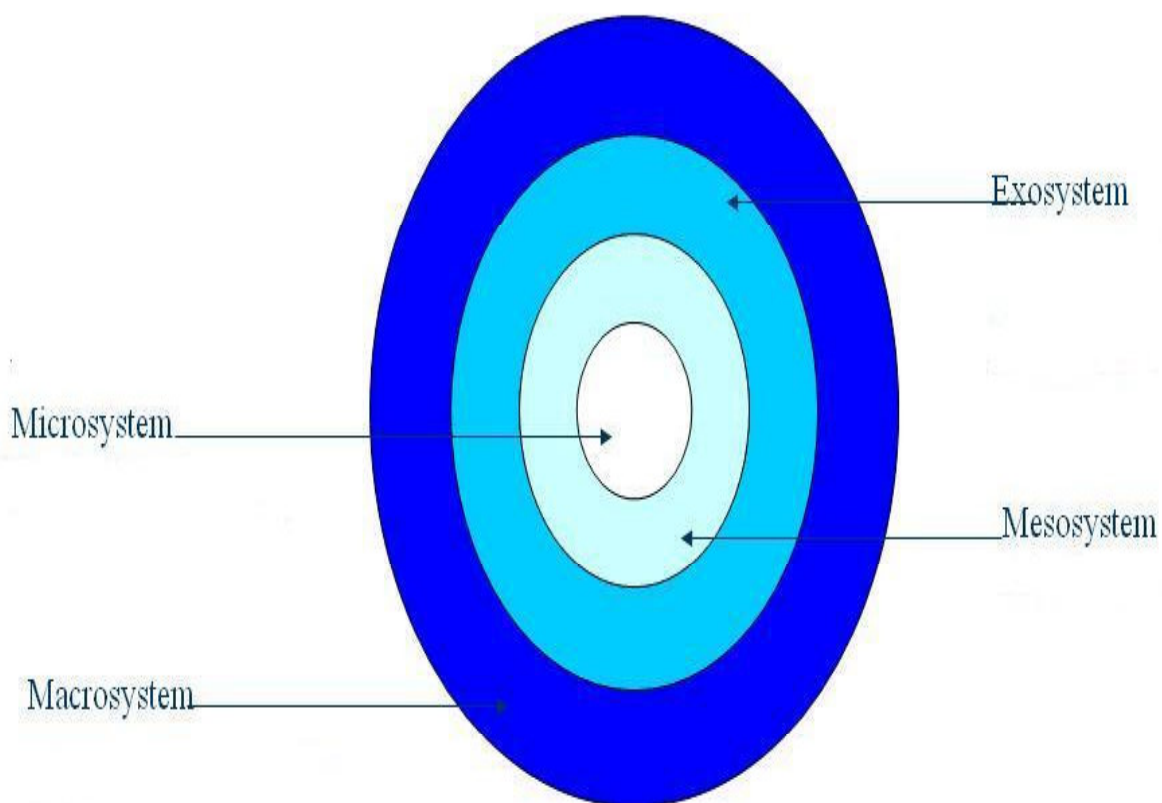

Figure 1: Bronfenbrenner's Ecological Systems Theory Model

3.2.1. The Microsystem

The innermost layer, closest to the individual is referred to as the microsystem. This represents the most direct and obvious relationships within the youth's experience because it occurs within the environment in which they live. Some of the relationships within the microsystem include family, friends, youth care workers, income assistance caseworker, teachers and charitable organization volunteers. These are interdependent relationships as the youth interacts directly with representatives of these social structures.

3.2.2 The Mesosystem

The ecological layer referred to as the mesosystem is when the youth interacts with structures outside the environment in which they live. This system is described as a set of interrelations between two or more settings. (56) The connections situated within this system specific to former youth in care include friends and their families; youth care workers and their social relations. The youth care workers' social relations help define their values and beliefs that in turn shape their interactions with the youth. As such, the youth care worker who values healthy eating practices would likely reflect these ideals in their communications with the youth.

3.2.3 The Exosystem

The exosystem layer is contextualized as the larger social system wherein the youth is not an active participant but she/he is impacted nonetheless. The structures within the exosystem affect the youth by influencing her/his microsystem and the impact can be both positive and negative. The relations at this level are primarily characterized by regulatory influence and control, which impact the youth's life and choices available therein. Some examples of exosystemic structures include child welfare and income assistance policies.

3.2.4 The Macrosystem

The outermost strata of the ecosystem framework is the macrosystem which consists of various guiding principles such as laws, customs, ideologies, societal values, social order and gender beliefs. These doctrines “defined by the macrosystem have a cascading influence throughout the interactions of all other layers.” (57) The impact of the macrosystem is evidenced in the youth’s lived experience. For example, the social perceptions of gender differences may result in placing a greater emphasis on teaching female participants the ‘traditional’ domestic skills.

The constructed realities of transitioned youth in terms of nutritional competency and food related experiences were examined within an ecological context proposed by Bronfenbrenner. (56) The constructivist approach precipitated an iterative process between the theory framing the study and the data collected. (58) Within the ontological position of constructivism, “the constructed realities ought to match the tangible entities as closely as possible, not, however in order to create a derivative or reconstructed single reality but rather, to represent the multiple constructions of individuals.” (59)

The premise that an individual’s worldly constructions as influenced by their environment, are multifaceted and complex align with the use of Bronfenbrenner’s Ecological Systems Theory. (56). This ecological framework is acquiescent, in that, individual reality dictates both the environment and the relations. For example, the relations with youth care workers can be described within the context of the microsystem or the mesosystem depending on individual circumstance.

3.3. Social Construction of Knowledge

Social constructivism is rooted in the belief that human thought is grounded in social, historical and cultural dimensions. Vygotsky's Social Construction of Knowledge theory posits that systems of knowledge are constructed at the social and cultural level and then reconstructed and tweaked by individual learners and inquirers. (54) Learning is fundamentally social in nature and takes place in a process moving from external control to internal control; a journey from other-regulation to self-regulation. (60) Relative to this study, youth care workers would presumably model behavior that the youth would observe, internalize and later adopt in a process of achieving self-reliance and independence.

3.4 Phase Theory

Phase theory as developed by Garfat, focuses upon the nature of the interactions with youth. In this context, youth care workers move through a dynamic process of "doing to", "doing for", "doing with" and then finally "doing together" as they spend more time in the field, gaining experience and personal growth. (61) It can be interpreted as a process whereby the youth care worker (the other) and the youth (the learner) move through a reciprocal learning continuum; the youth, over time gains more ability ultimately becoming 'response-able' meanwhile the youth care worker becomes more comfortable in their role as a support and guide.

3.5 Researcher Identity

The fundamental role of the researcher in qualitative inquiry is that of inquirer and interpreter. The inquirer's voice is that of a "passionate participant actively engaged in facilitating the 'multivoice' reconstruction of his or her own construction as well as those of all

other participants. (62) Therefore, it is vital that the reader of this research is offered some insight into the researcher's frame of reference.

I have worked within the child welfare milieu for 13 years as a 'front line' youth care worker. The majority of my career was spent working with young women who were on the cusp of transition to independent living, because of either aging out of, or self-determination to move away from, the child welfare system. During this time, I experienced many frustrations symptomatic of a system over-burdened by the challenges of preparing youth for transition to independent living.

Through my career as a youth care worker I gained knowledge and understanding of the typical transitional experience in terms of outcomes such as homelessness, drug abuse, poverty, food insecurity and poor health. Now, as a nutrition student, I naturally began to question the effectiveness of life skills programming as offered within the group care facility. I began to seek out the best approach to teach the youth basic nutritional competencies and was surprised when I concluded that passive learning in the form of observing or sharing stories seemed to be the most effective approach. Although group facilities offer life skills training of nutritional competencies such as cooking, grocery shopping, safe food practices, in my experience, these programs rarely seem to work. While the reasons are many it appeared that apathy on the part of youth and youth workers and the youth workers' general lack of skills or knowledge concerning nutrition were key factors impacting success in achieving nutrition competence.

Although I have drawn some conclusions based on my extensive experiences in the field, I have limited knowledge on how the youth are able to apply the nutritional competencies as learned passively, as described or actively in the form of a life skills program. The literature concerning follow up of former youth-in-care rarely addresses nutritional competencies and food security experiences with any detail. However, I believe that once this topic is exposed and

scrutinized, that programs and policies can be established to better meet the needs of these young people that are often caught between the child welfare system and adulthood, with no strong footing in either system.

CHAPTER IV: METHODS

4.1 Naturalistic Inquiry as a Qualitative Approach

The purpose of this research was to gain a better understanding of nutritional competency and food related experiences of youth living independently following transition from residential group care using a naturalistic inquiry approach. Guba and Lincoln (63) refer to this qualitative approach as an effort to understand and describe the perspectives and experiences of the participants in the context within which their experiences occur. As such, this study explored the participants' experiences and interpretations of experience from a dual perspective: within the youth care milieu and post-care independence. Through the exploration and understanding of the transitional experiences of youth leaving congregate care settings, programs and policies can respond to better meet their needs.

Qualitative methods of data collection were particularly suited to this research. Face to face interviewing and field note journaling provided media to gain a deeper understanding of the phenomenon of transition and the impact on nutritional competence and food security experiences. The Household Food Security Survey Module (HFSSM) was used to screen for incidence of food insecurity. (42) This research was approved by the University Ethics Review Board of Mount Saint Vincent University

4.2 Sampling Procedure

Participant selection was guided by purposive sampling. Patton (64) states the logic and power of purposeful sampling lie in choosing information rich cases for study in depth. This technique allows the researcher to identify participants with certain characteristics and experiences that represent one or more perspectives deemed relevant to the research goals. (64) The three inclusion criteria for youth participants were first, they had been in Child Welfare

Care; second, they had lived in a residential youth care facility for at least six months; and thirdly, they had lived in congregate care facilities within the previous two years. Initially, the study design excluded those who had lived in supervised apartments because it was reasoned that these youth would have more advanced nutritional competency and life skill training. However, as data collection proceeded, it was decided that the inclusion of these youth would be insightful and potentially provide a negative case analysis. Following an ethics approval revision, youth who has resided in semi-independent facilities were included. The selection of youth care facilities was based on common mandates or practices to prepare youth for transition to independence.

4.2.1 Sample Size

In a naturalistic inquiry, there are no basic rules that direct decisions surrounding adequate sample size. Qualitative research seeks more quality than quantity and information richness in lieu of information volume. (65) The number of participants is not clear at the onset of the study thereby sampling was guided by principles of saturation (64), which occurs when an increase in sample size does not generate any new themes.

4.3 Data Collection

The data collection involved a triangulation of methods that offered strength and credibility to the findings. (55, 59) Data sources included in-depth interviews with both youth and youth care workers, responses to the HFSSM on food security and field notes.

4.3.1. Interviews

In order to create awareness about the study, posters (Appendix A) were displayed in locations frequented by youth; locations included ARC (a drop in center for youth), Parker Street Furniture Bank, and two youth care facilities. The placement of the poster within the residential facilities was to create awareness of the study among youth care workers, so they, in turn, would be able to provide information to former residents. This was done to increase the potential pool of participants. Following a review process, posters were placed at two Phoenix Youth Programs.

The poster presented a summary of the study along with contact information. Those who expressed an interest were offered a letter (Appendix B) that provided further details of the study. Thereafter, the youth who were still interested were asked some screening questions to determine eligibility. Those who fit the criteria were then asked to meet for an interview.

Due to confusion during the screening questions, two youth who did not fit the inclusion criteria were interviewed. During these interviews, it was discovered that the youth had not been involved with Child Welfare Care, as initiation of services came after their 16th birthday. The first of these interviews served as a pilot test.

Within naturalistic inquiry, interviews are in the form of a dialogue or interaction, which helps the researcher to understand and put the interpersonal, social and cultural aspects of the environment into a larger context. (65) This study used a semi-structured interview approach

The interviews were conducted at a location suggested by the youth, for reasons of convenience and establishment of a safe relaxed atmosphere. As a result, four interviews were conducted in a large park, two in coffee shops and one in an apartment. Interviews with youth care workers were held within the facility during daytime hours. This setting allowed for observation into the operations and layout of the facility thereby providing a context to the

interview responses. As expected when interviewing within a place of business and activity, there were interruptions to the interview that may have detracted some of the flow and cadence of the conversation.

Prior to the interview, the youth participants were informed of the nature and intent of the study. The informed consent form (Appendix G) was then read aloud and key elements were emphasized such as assurances of confidentiality and anonymity, voluntary involvement, right to decline answering any question and their right to withdraw at any time without repercussions. Further details regarding their interview such as storage, destruction and transcript review were also discussed at length. Following the review of the informed consent, the youth were asked if they had any questions or concerns. At this time, potential participants were asked if they wished to take part in the study. Those who agreed were then asked to sign the consent and permission to audiotape forms.

The recruitment of youth care facilities was initiated by telephone, at which time permission to forward a letter detailing the study was requested. Within two weeks, a follow up telephone call confirmed the participation of three facilities. At follow up, the supervisors of three other facilities stated that the letter detailing the study (Appendix C) had been forwarded to their executive directors or program coordinators for further review. Of the three, two facilities agreed to participate, the other declined due to scheduling conflicts.

The process for obtaining informed consent from the youth care workers involved a verbal description of the study that again emphasized assurances of confidentiality, anonymity, voluntary involvement and member checking of transcripts. After answering questions or concerns, the worker was asked if the interview could proceed. At that time, the youth workers were asked to sign a copy of the informed consent (Appendix H) and permission to audiotape forms. (Appendix I)

All the interviews were audio recorded using a digital voice recorder. The digital recorder may have created some discomfort but these effects appeared to be minimal. Prior to beginning each interview, youth respondents were shown how to pause the recorder in the event that an abrupt stop was necessary. This allowed the youth control over the recording and I feel helped create a more relaxed atmosphere. At the end of each interview, participants were thanked for their involvement and the youth given a monetary gift.

4.3.1.1. Interview Scripts

The objective of a naturalistic inquiry is to generate a dialogue or an interaction to gain a deeper understanding of a particular phenomenon. (65) To facilitate this dialogue, interview scripts were developed based on the literature review and the objectives of the study. Specific to the youth participants, an interview script (Addendum D) was crafted to encourage a thick description of their transitional experiences in terms of nutritional competence and food security. Similarly, an interview script (Addendum E) was developed to explore transitional life skills programs from the youth care worker perspective.

Both interview scripts were pilot tested for readability, comprehensibility and relevance prior to use. The pilot test was completed by a youth who had not been in custodial care, another who had resided in a residential care facility and a youth care worker currently practicing in the field. In terms of the youth care facilities, the interview script was pilot tested by a youth care facility supervisor. The individual responses from the pilot test were not included in the research results. Based on feedback, the youth focused interview script was altered to clarify the three components of nutritional competency.

4.3.2 Field Notes

A field note journal was maintained to enhance data interpretation through reflection and self-awareness. This journal recorded observations and impressions that could not be reflected in the voice recordings. The journal entries helped contextualize the youths' struggle by the documentation of their physical and emotional presentation. As I became more involved in the data, I would often write notes on bits of paper, documenting ideas and impressions about the study. These memos also served as a type of field note that helped shape and inform the remainder of the study.

4.3.3 Household Food Security Survey Module

Participants' food security was assessed through the HFSSM (Appendix F) used in the 2004 Canadian Community Health Survey, Cycle 2.2. (42) The questions and method of analysis used in the HFSSM were adapted from food security measurements developed in the United States. (66). The HFSSM is based on self-reported uncertainty, insufficiency and inadequacy of food availability, utilization and access due to limited financial resources. (42) For the purpose of this study, the HFSSM was comprised of ten questions specific to adults in the household. Responses were recorded and a code that corresponded to interview transcript was assigned.

Data from the HFSSM were analyzed to determine the prevalence of food insecurity and act as a gauge to contextualize each participant's situation and by extension, interview responses. Descriptive variables such as, source of household income, age, highest level of education and number of transitions while "in care" were considered in context to the HFSSM responses.

The HFSSM uses three categories to describe the food security experiences of the respondents over the previous twelve months: 1) food secure; 2) food insecure, moderate and 3) food insecure, severe. Food security status was determined by the number of affirmative

responses to the questions. A response was considered affirmative if the participant indicated 1) “yes”; 2) “often” or “sometimes”; or 3) “almost every month” or “some months but not every month”.

4.4 Data Analysis

Data analysis and data collection were complementary activities as themes identified in the initial data analysis were used to guide future interviews. For example, the ability and influence of youth care workers on nutritional competence became an area of further exploration in the youths’ interviews.

The digital recordings were transcribed verbatim and marked by the same numerical code given the voice recording to ensure confidentiality. Following transcription, I read the document without making any notes. The intention was to re-acquaint with the interview and gain a sense of the words as spoken. After multiple reviews of the transcripts, recurring themes were noted; these would provide a foundation for the emergence of categories. A summary of each transcript was written and cross-referenced with the field notes to determine if initial impressions were congruent then additional ideas, themes and impressions were recorded.

The conclusion of the data collection and subsequent completion of transcription activities marked the beginning of the coding procedure. I began by reading each interview, highlighting phrases, sentences and at times complete paragraphs that presented as themes and areas of significance within the interview. Thereafter, the highlighted comments, words and phrases were copied to index cards and given a label that provided context. This was a labor-intensive task as my inexperience reasoned for the adoption of the mantra, ‘more is better’. The index cards were then spread out across the floor, and common phrases/themes as shared in

various contexts were grouped together. This process was repeated using the interviews with youth care facility representatives.

Following the sorting of the cards into various groups, the piles were reduced by the elimination of duplicate phrases and comments. Then the coded themes were compared and re-considered to ensure fit. This resulted in a reconsideration of the initial categories. The data groups began to connect and form a category that contextualized previous categories. A sample of the coding process from raw data to category development is shown in Appendices, Table 3.

4.5 Quality of Data

The aim of naturalistic inquiry is to produce thick, rich, descriptive data that enhances the understanding of a phenomenon. The value of the research is dependent upon the rigor and credibility of the data in that the data are trustworthy and reflective of the intended meanings and experiences of the participants.

4.5.1. Credibility

Researcher credibility is based on a principle “to report any personal and professional information that may have affected data collection, analysis, and interpretation; either negatively or positively.”(55) The field note journal wherein I reflected on the research process was a helpful exercise for understanding the data.

Through the transcription of the digital voice recording, I had a further awareness of my reaction and presentation throughout the interviews. As such, this self-awareness allowed me to recognize my various reactions in the moment and adjust future interviews and inflections of personal bias accordingly.

To establish peer review, I discussed findings and possible interpretations with my thesis advisor. A second coder, who was familiar with qualitative research and currently employed in the youth care field, coded a selection of interviews (two youth and one youth care facility representative). Interpretation of the data was enhanced by through comparison of the HFSSM .responses and the youths' interviews. Finally, conversation with secondary informants employed in the youth care field and aware of transitional outcomes provided additional confirmation and insight into the data analysis.

Every participant was given the opportunity to review his or her transcript as a means of member checking. The facility representatives requested and received a copy of the transcript for review. One participant voiced concerns about the transcript in terms of the verbatim representation of words such as 'cause' in lieu of 'because'. Assurances were given that there would be no identifying information associated with those words. This seemed to relieve the participant's concerns. The participant confirmed that the information had been correctly interpreted and the verbatim dialogue was the only issue.

Although offered, none of the youth respondents wanted a copy of the transcript for member checking. I did seek permission to retain their contact numbers in case any clarifications were warranted. All of the youth gave permission to contact them but this was necessary.

4.5.2. Transferability

Transferability refers to the degree to which the results of a study can be applied across settings or used with different populations (59). Many researchers, primarily concerned with a particular sample and setting, do not attempt to generalize their findings beyond their own research. Specific to this study, a detailed description of the participants and the research design is provided so that interested individuals can assess transferability to their particular interest. As

such, in addition to methodology as detailed in this chapter, a portrayal of the youth participants is given in Section 5.1.

In the interest of confidentiality, detailed descriptions of participating youth care facilities are not shared however a general over view is presented (Table 2). Interested researchers can investigate the relatively small numbers of youth serving organizations within the Halifax Regional Municipality to determine transferability.

4.5.3 Dependability

Due to the subjective nature of naturalistic inquiry, bias can occur. As such, data need to be confirmable to ensure that the intended meanings and perspectives are accurately reflected. The audit trail was a key strategy to insure dependability, as it created ‘a pathway between the collection of data and its use’. (55) Dependability was achieved by maintaining a written account of the research process including any edits, ideas or alterations to the study. An audit trail, consisting of a field note journal, interview summaries and jot notes that recorded changes in thoughts, impressions and decisions made throughout the research process, was kept to enhance dependability.

4.6 Research Reflection

Naturalistic inquiry is ‘value-bound’ in that it acknowledges the influence of personal experiences and beliefs of both respondent and researcher on the perception and interpretation of the data. As stated *a priori* to the study, I had been a youth care worker for many years and this fact turned out to be both a hindrance and a help to this study. Constant reflections on the influence of personal experiences on data interpretation were essential to identifying potential bias. By way of example, I will share one finding that caused an emotional reaction and perhaps

became a defining moment in assuring I was listening and interpreting with an emphatic ear. As a youth care worker and nutrition student, I focused intently on the quality of menus within the youth care facility and throughout the organization where I worked. My intention was to provide the youth with nutritious well-balanced meals. When I began interviewing, I felt a sense of pride and accomplishment when the first youth interview identified the youth care facility menus as catalysts for learning healthy eating. Later in discussing transitional experiences with homelessness and food insecurity and it was evident that the menu practices I embraced and encouraged within the group home could not be achieved, despite the youth's best efforts. This became a resounding theme throughout most of the interviews and I was struck by my ignorance despite many years in youth care and overwhelmed by feelings of personal responsibility for my contribution to the youths' struggles.

4.7 Ethical Considerations

Attention to ethics was essential to this research because of the involvement of the participant's values and lived experiences within the inquiry. It was paramount that the participants were not only aware but understood the study. The potential to encounter low literacy skills was considered and thereby in addition to a verbal reading of the informed consent form, an interview preamble reiterating the intentions and voluntary nature of the study was also read aloud.

There did not appear to be any potential risks for the youth involved. They were advised of my obligation to report any abuses they disclosed. The nature of the study as related to custodial care experiences had the potential to cause upset or stress, thereby a youth counselor would be available for de-briefing if required. None of the youth expressed any concerns. To assure confidentiality was maintained in this small sample, identifying details were omitted from

comments. As well, the attachment of a pseudonym to the participants' remarks was avoided because it would be possible to trace comments back to a single individual.

CHAPTER V: RESULTS and DISCUSSION I: TRANSITIONAL LIFE SKILLS

5.1 Participant Demographic Characterization

Seven youth consisting of four females and three males ranging in age from 19 to 26 years (mean age = 22) participated in the study. On average, the youth participants experienced seven placements while in custodial care and the length of time in the child welfare care ranged from nine months to eight years. At time of discharge, the average age was 18.5 years. The educational accomplishments of the youth participants varied from completion of grade 8 to first year of college. Sources of financial support were Income Assistance (5/7), fulltime work (1/7), and primarily full time work with periods of part-time work (1/7). A summary of the demographic information related to the youth participants is included in Appendices Table 1

In total, five participants representing four youth care associations within the HRM were interviewed. The facility profiles included one co-ed, two male and two female. All offered life skills programs and interventions but differed in their delivery. None of the participating facilities had a formalized comprehensive independent life skills program. A summary of the demographic profile related to the youth care facilities involved in the study is included in the Appendices, Table 2

Mapping of Custodial Care Influences

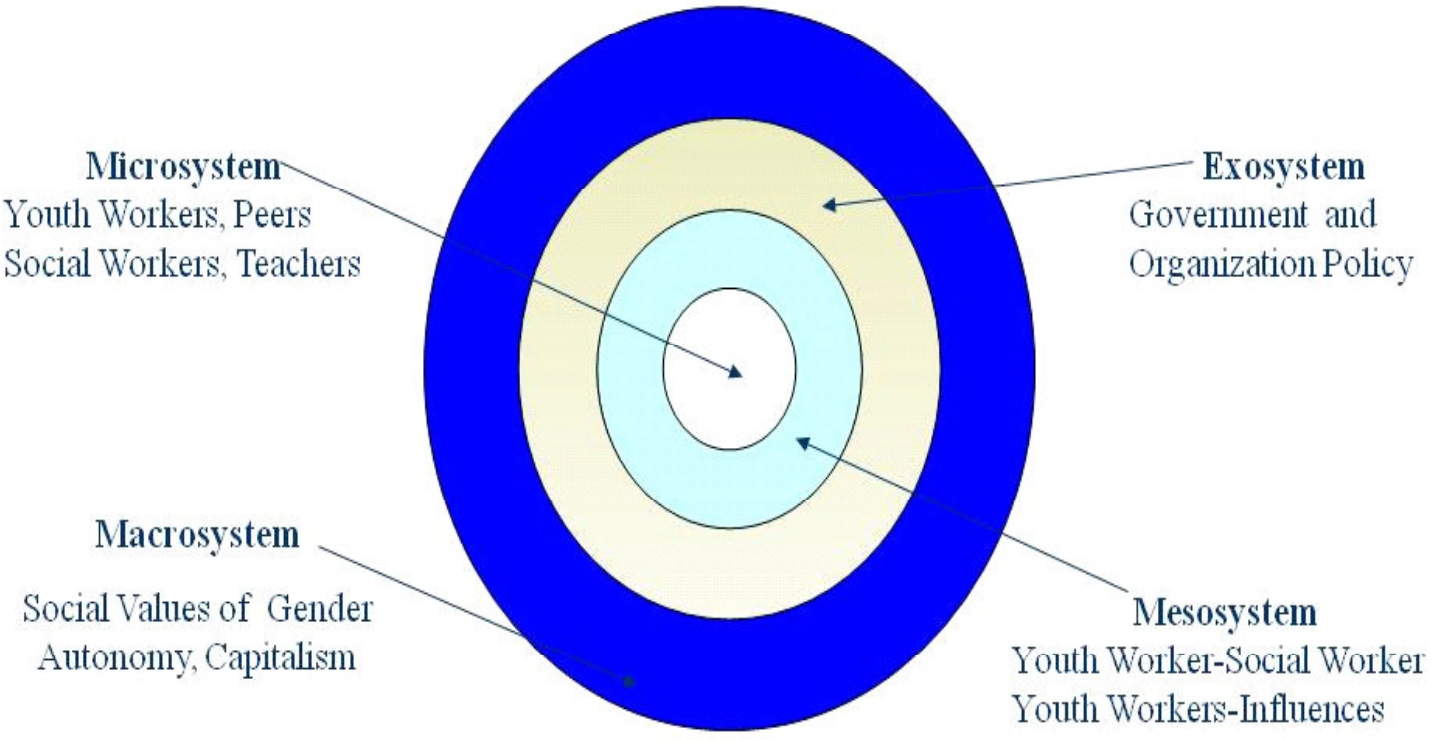

Figure 2 Custodial Care Influences

Nutritional competency development within the youth care environment was affected by various influences; some were within the participants' control while others were not. The following chapter will discuss the four spheres of influence, *environmental, personal, external and social* in the context of Bronfenbrenner's Ecological Systems Theory. (56)

5.2 Youth Care Facility Environment as an Influence

The youth care environment was a significant influence on the youth participants' nutritional competency developments and the youth care workers' ability to provide this training. The development of nutritional competency within this environment was dependent on many factors such as the youth care workers knowledge, approaches to teaching life skills, presence of other youth and finally the youth care atmosphere itself as guided by governmental and organizational policies and standards of operation.

5.2.1 Portrayal of Residential Youth Care Facilities

In order to assess the impact of the independent life skills programs on nutrition competency, it is necessary to understand the young persons' experiences and perceptions of the environment within the facility. This will provide the reader with a context to understand the learning atmosphere including the barriers and enablers of life skills program delivery.

The lived experience within the youth care setting is highly subjective shaped by life circumstance, emotion, and facility organization; experience and perception can shift in response to environment, age and circumstance. It is a dynamic environment, with constant change in staff and residents. Furthermore, these facilities are purpose built (17) to provide a secure environment and to act as transitional bridges back to family or community; in summary they are temporary placements wherein youth live in varying states of transition.

By way of general introduction, the youth care environment was described as a time of little responsibility and an atmosphere where basic needs were met.

They deal with the most basic of things you know, sleep here, here's your meals and do your laundry, other than that whatever.

When you are in care, you're kinda taken care of.

Living in a group home, you have somebody doing it for you ...

It was all fun, that's what it felt like

The youth were united in the nutritional characterization of the youth care facility, with most participants crediting the food practices for teaching them healthy, balanced eating. Generally, the food within the youth care milieu was described as healthy, abundant and convenient.

Just eating what's good for you because you don't really get junk food in the group homes, your junk food is even kind of healthy.

There was always food in the cupboard and someone there cooking it for you.

Representatives from the youth care facilities concurred that the food choices were selected based on the perceived nutritional value of the product.

We are not going to buy a box of McCain pizzas to cook for their meal. That to us, is just not healthy and usually we don't provide that stuff

Youth care facilities, bound by regulations and standards of government licensure, are required to model their menus in accordance with Canada's Food Guide. Since the facilities strive to provide a safe, secure atmosphere that fosters well-being, youth care facilities provide a food secure environment.

5.2.2 Nutritional Competency Development within Youth Care Facilities

For many youth participants, the development of nutritional competency was influenced by many people, situations and environments. Since all of the youth had more than one child welfare placement, their skill level was not always attributed to one person, place or time. While the focus of the interview was learn about developing nutritional competency within congregate care settings, it is recognized that the youth were influenced by experiences pre and post group care. In this regard, the interview questions exploring this theme were prefaced with *looking back while you were in group care...*

5.2.2.1. Food Skills

With respect to food skills such as cooking, grocery shopping, baking and menu planning the participants referred to specific programs they experienced while living in group care. Mainly these programs were incorporated into the youth care facility's daily programming and thereby considered a mandatory activity.

Like in some of the programs, there was like one night a week where you had to make a meal for the entire house.

I could go grocery shopping at the house; like I would get grocery money, go shopping, and buy those things.

Several youth identified grocery shopping and budgeting as competencies they had not mastered prior to leaving group care. Some programs sought to teach these skills in the abstract by perusing flyers and spending hypothetical budgets. These programs were ineffective because they were simplistically oriented to a pen to paper exercise based on mathematical calculations as opposed to a comprehensive tactile approach requiring complementary skills of social interaction, and activity co-ordination.

5.2.2.2 Nutrition Knowledge

Most participants attributed their knowledge of healthy, balanced eating and basic understanding of Canada's Food Guide to the menu plans offered at the youth care facility.

Like growing up and a lot of it from the group homes and them making us eat balanced meals rather than popping something into the microwave. It always had to be something nutritious.

I've just always known about the food guide but not only that but just like from group homes too. They always had nutritional meals.

Some respondents recalled seeing the Food Guide posted within the youth care facility yet they did not have any further recollections. Only one youth respondent made a specific reference to safe food handling practices.

5.2.2.3 Awareness of Nutrition and Food Related Resources

While residing in residential care, most youth were familiar with community resources primarily related to food access such as food banks. When questioned on how they acquired the

information most youth could not recall an exact conversation or a manual that referenced these resources. They seemed to just know about community resources such as food banks, Phoenix Youth Programs, soup kitchens and supper churches, as extensions of the youth care culture. Some of the participants had experiences with food banks prior to their involvement with the Child Welfare Care System.

5.2.3. Limitations of the Youth Care Environment

Generally, most youth indicated that their nutritional competency was limited to cooking skills, knowledge of healthy foods, and awareness of places to access free food. For the most part, complimentary life skills as realized through experiential learning opportunities were lacking. The incorporation of experiential learning opportunities into life skill programs were limited by operational needs; government licensure policies and financial restraints. Several youth care workers stated that standards and regulations restricted their freedom and consequently their ability to offer comprehensive life skills programs. The freedom to focus on life skills was compromised by facility operations such as staffing protocols, financial accountability, administrative tasks and operational priorities. The following comments discuss how staffing ratios necessitate the juggling of administrative duties and direct youth interaction, to the detriment of life skill programs.

Sometimes you feel like you're just stretched. You know [so and so] is supposed to be cooking tonight and we're supposed to be supporting and helping in the kitchen ahhh but you know, [so and so] down the hallway is having a bad time, so you stretch your time trying to do multi-tasking and sometimes things get put aside

Themes of being ‘in the moment’ and ‘hands on’ suggested that these interactions with youth were an effective approach to skills transference. Yet, despite the emphasis on these themes, the daily flux of staff was counter to the creation of an “atmosphere of normalcy”. Within this dynamic environment, youth lose the opportunity to observe and learn from one or two role models. It is a learning experience with many teachers, many styles and many approaches.

I think what we recognized as a facility what we may be missing is some of those life teaching things, the normalcy you may have gotten from watching a parent do some house maintenance or something along those lines.

The organizational structure of the youth care environment precipitated the creation of life skills programs that were limited in scope, to the exclusion of pertinent skills such as, decision-making, time management and social interaction, which became evident once transition occurred.

Within the youth care environment; freedom to make decisions is limited by group norms that guide the facility operations. For example, the youth are not able to take the food budget and experiment with grocery shopping, attainment of skills through trial and error comes at the expense of the group and thereby is not feasible. As such, youth residing in congregate care environments are unlikely to gain practical experience in tangible life skills simply because of the daily operation of the environment.

5.2.4 Approaches to Nutritional Competency Programming

The approaches to nutritional competency development varied in response to facility organization and youth experience. The type of approach to promote life skill development was

considered antagonistic, favorable or inconsequential depending on the individual.

Although some facilities reported similar approaches to nutritional competency development, they all differed in terms of emphasis as influenced by staff interest or facility expectations.

Through data analysis three approaches to teaching life skills within the congregate care environments were identified: *collaborative, structured and informal approaches*

5.2.4.1. Collaborative Approach

The facilities representatives described the process of preparing youth for independence as a collaboration involving the youth; their social worker and the youth care team. Usually, the process began with a discussion of the youth's abilities and needs required within an established timeline. Once identified the life skills are incorporated into a "*treatment plan*", "*care plan*" or "*personal program*". As the skills were realized, the plan evolved to reflect accomplishments then progressed onward. Although most youth care workers made reference to this approach, the following comment would suggest this was not an ideal forum to discuss transitional planning:

They are always involved in their care plans while they're here. The difficult part sometimes is trying to find ways to give them opportunities to make positive decisions for themselves and to be, you know, a productive participant in a care plan meeting where oftentimes the meetings are overshadowed by anger and frustration.

Conversely, none of the youth participants identified care plan meetings as opportunities to make decisions regarding their nutritional competency development. This calls to question whether the care plan meetings are effective in determining individual life skill needs. In the absence of individualized program or a skills checklist to benchmark competencies, the

incorporation of mandatory life skill activities into the facility's daily routine would amount to a cookie cutter approach to life skills development.

The lack of consensus regarding the value of care plan meetings as a forum for transitional planning would suggest that this approach is ineffective in meeting the youths' needs. An evaluation of care plan meetings would help determine how this approach can evolve and become more effectual in transitional planning.

5.2.4.2. Structured Approach

A structured approach to nutritional competency, incorporated life skills into daily household events and activities. For example, several youth participants described programs whereby weekly food preparation tasks such as cooking and menu planning were facility expectations. In their description of this approach, two of the youth participants stated that they had cooked the same meal every time.

Like I was saying before, it was always rice and ground beef and veggies.

There was a thing that they called Resident's Specials and every week a certain resident would get to cook a meal for everybody.

(VB): Ok and did you do that?

Yeah, I always made tacos [laughs] Everytime! It was the only thing I knew how to make.

These comments would suggest that the expectations of the life skills program were limited to simply doing the chore as opposed to expanding one's knowledge and skill base. As such, a structured approach to life skill development can be shortsighted and ineffective if previous experience is not considered. While it is important that the youth participate in daily

household activities, if the scope of the life skills program is limited to activities previously mastered, then relevance is lost. The following comments by one youth illuminate the insignificance of this approach to life skill development:

There's a couple of things you can learn and whatnot but everything that they're teaching you is stuff that I had to learn even before hitting the group homes. You know

Another participant shared this opinion on using a mandatory approach to life skills programming:

You can't force it on anybody. They're not going to want to learn it that way and especially if you take into consideration the mindset of the people who are in a group home; most of them have real problems and they don't want to hear it, you know

Yet, for other youth, a mandatory structured approach to life skill development was recognized as a positive influence on nutritional competence.

I kind of gained a little sense of it doing it my own self and with cooking; I'd have to say that it came through all the group homes. I guess 'cause I was just always around the kitchen when they cooked and asked questions. But if I had to pick one I'd say (facility name)' cause it was more hands on like where you have to do it.

The negative impact of complacency on nutritional competency development would suggest that mandatory programs rooted in experiential learning are beneficial. The following comment by a youth participant accentuates the value of mandatory programs as a strategy to engage the youth in learning these skills.

A few more program where the youth have to be involved in the meal preparing and going to the grocery stores and learning the skills like that. It's a lot better because that prepares them and teaches them how to do that on their own rather than being like ok, well I'm used to having all these meals made and then move out on their own and go, who's' gonna cook...I don't know how to cook or go shopping. Who's gonna do that for me?

The structure of the youth care facility dictates that food needs to be available and meals provided; ultimately this is the staffs' responsibility. In the absence of a mandatory approach, it can be posited that youth would remain disengaged and complacent; content to forgo nutritional competency development and rely on staff obligations to ensure food availability.

5.2.4.3. Informal Approach

In contrast, some facilities used an informal approach to life skill development, whereby there was no expectation to participate; the primary motivation was to share time and company. One facility representative shared the strengths of this voluntary interaction using daily life events to teach life skills:

We try to take those moments and those opportunities just to share with the kids so it isn't just an imposed thing where you have to do this, where again they feel powerless and they feel, you know, we're being the boss of them kind of thing. It's more like a side by side, together we'll do this and then as a result what usually happens if you are successful with it, there's nothing left because they prepared it.

The voluntary approach to life skill development resonated with some youth participants who noted that being present while youth care workers prepared meals had an impact. These occurrences were voluntary and as such not part of a program expectation.

Cooking with staff, like if they're cooking then we could cook too and help with them. It was more like an interaction. It was helpful.

These interactions between youth care workers and youth facilitate learning through adherence to Vygotskian principles of knowledge construction. (54) By way of observational and experiential approaches to learning, the youth internalized processes of achieving nutritional competence and adapted the information to regulate their own activity. This process of building knowledge based on environment, calls to question the extent, by which, the workers' influence and knowledge can direct the youths' nutritional competence.

Despite differing approaches and with full recognition that each program has a unique philosophy and culture guiding transitional life skills programs, most representatives indicated that an early initiation to life skills training would contribute to the youth's ability over time. As a result, the skills would be developed as an on-going, natural learning as opposed to being directly related to an urgent need to prepare for transition.

5.2.4.4. Youth Engagement Strategies

The challenge of engaging youth in programming was recognized by all participants. Several youth suggested strategies to entice participation in life skill programs.

Well there's always incentives right, like honorariums or whatever incentives that work I guess; food money, whatever. I know there's not too much money but food would work.

If you just make a little game out of it, it's more fun.

...that was a lot of the learning I went through with games and jokes and things like that.

These suggestions align with principles of adolescent education whereby effective programs are modeled in accordance with the youths' psychological and social development. Transitional life skill development involve tasks that are future oriented and for many, beyond their cognitive ability to be recognized as important. Thereby the approach to teaching can have a significant influence on youth engagement.

5.2.5 Youth Care Workers Role

The function of the youth care worker as a mentor and role model influenced youth engagement in life skills programs. Youth care workers, ultimately responsible for decisions surrounding menu planning, food procurement and preparation; inadvertently become teachers simply by their food related activities within the youths' immediate environment. These daily life events provide opportunities of interaction (27) that enabled the youth to experience the world in a different way. In this role, the youth care worker can be a positive or negative influence based on their knowledge, interest and personal beliefs and values.

Some youth did not consider the youth care worker to be interested in their nutritional competency and life skill development. As evidenced in the following comments, the youth care worker was described as just doing a job:

They get paid to look after you while you're there. You know, they have a job to do and they do that

In many ways, the youth care worker's role is limited to the custodial care environment and their job within it, as organization policy restricts the continuation of the relationship once discharge occurs. Following discharge, the youth are required to adjust to the departure of youth care workers as a mentors and supports.

Others indicated that the youth care workers did have a significant role in their life skills development and transitional experience. These influences ranged from providing information and advice to helping the youth work through challenges.

With the group homes, there are a few things they helped me with. It's more like a dictionary, you know or a source of information if I ever forgot something.

They were very supportive and helpful

My key worker at [locale] was the most helpful. She tried to help me prepare for it and where she knew what it was like moving out on your own so she'd be like this is going to come up so we'd work through that.

Specific to nutritional competency development, one youth suggested that the youth care workers were not positioned to take on this role because they lacked knowledge and expertise in this area.

Everyone was kind of on the same level, which wasn't too high, food wise anyways, so everyone seemed to know the same amount of things when it came to that. The staff were just about as disinterested at the time as we were. They're not cooks and a lot of people really don't like cooking right.

This observation was noted by the majority of facility representatives who suggested that the lack of knowledge limited the development and dissemination of independent life skills programs. Nutritional knowledge, ability and interest varied among the facilities and individual staff members. Presently there is no baseline knowledge required for employment in the field as reflected in the comments by one youth care worker.

It's one of those assumed things again that when you bring an adult into the role of a youth care worker that they know how to prepare meals.

The influence of the youth care worker as a role model was also raised as a concern in that nutritional beliefs and practices were not always positive messages.

People coming in with their own values and belief systems around food; oftentimes I am concerned about youth care workers coming in and talking about diets and dieting and what their thoughts are on proper nutrition in comparison to what really should be taught to the young people.

Another facility representative expressed caution about relying solely on staff and ensured that youth are also connected with professional services in the community.

So we don't solely rely on the staff knowledge; there is currently a great bunch of staff that are really health conscious and into nutrition and different things of that nature, so they have a lot of knowledge. But we make sure that the kids have the right connections

The challenge was further compounded by a natural tendency to project personal beliefs and experiences onto others. This was acknowledged by one worker who stated that assumptions related to the youths' abilities limited the success of life skills programs.

I think that we make assumption as to what the young people are actually capable of doing and also have an understanding of already; even things as simple as learning how to do laundry or literally cooking a meal, opening a can up with a can opener. I mean these are things that literally they really do not have the skills in. They really don't even have the skills to be able to understand how, where's the equipment, what would I need to even be able to start that process.

Within the youth care environment the staff have a significant influence on the facility's nutritional practices. Generally, the youth care workers organize, plan and perform all aspects of food service within the facility. As such, youth develop nutritional competence within the parameters as constructed by the youth care workers. Building on this influence, several youth participants suggested that the youth care staff assume a more active role in preparing youth for transition.

So you take them out and just show them how much things really cost.

The influence of youth care workers in modeling behavior to demonstrate healthy eating and food related skills was considered to be particularly effective in the youths' nutritional competency development. Many youth care workers believed that a greater emphasis on nutrition knowledge and skills training for new entrants to the field would be beneficial. It was suggested that this process could be incorporated within the student's academic studies or inter-organization training.

I would love to see the staff have a nice training module like nutrition, like even the new ones that are going through the college and stuff like that, you know to have that as a component.

(VB): What strategies do you think would further develop the nutrition apart of your life skills program?

So I think part of that would be for me training the youth care workers before they even come through the doors as to that component or even making that component part of our training process. So the orientation process that they become involved in a Food Handlers Course, for example even just for the safety component of preparing food.

The organizations interviewed did not have a staff training requirement specific to food related skills and nutrition knowledge; albeit some facilities did fund training in the Safe Food Handler's course but this was not a mandatory requirement of the job. Conceivably the opportunities to develop nutritional competence were limited by the knowledge of the individuals within the immediate environment. As such it is important that the youth care worker is supported in achieving their own nutritional competence so that they may model and share this knowledge and skill.

The academic course load of some Child and Youth Study programs do have a basic nutrition course requirement. This practice provides a template for other programs to consider in their education of future youth care workers.

5.2.6. Peers

Peer influence within group home environment impacted learning of transitional life skills. The influence of other youth was described as both enabling and limiting to the acceptance of life skill activities within the facility:

They see the others doing it too so it's not just them. The others will be like; it's not that bad

(VB): So does peer influence play a role here?

Yes, very much so. Cause I find the newer ones will really look up to those who have been here for a long time.

Generally, the youth care environment is marked by constant change in terms of youth and staff. Some youth, by virtue of age or placement duration, will become role models to newer or younger peers within the facility. As is the case with staff role models, these youth can have a negative or positive impact on nutritional competency and transitional life skill development. One youth participant expressed frustration with congregate care experiences of dealing with peers who did not share similar values regarding cleanliness.

(VB): Can you tell me about any food related skills you remember learning while living in the group home?

Well the whole thing was about...I hate seeing people put their plates in the freaking sink and not rinse it off...it pisses me off. I like, ummm my teenage year was all around that, nobody washed their plate or put it in the dishwasher. It was like ok, we all eat here, keep it clean!

5.2.7 Limitations of Time

The expression of time as a barrier to nutritional competence and transition planning was reflected in the youth care workers' interviews. The mastering of life skills was considered a time dependent task whereby youth with stable placement histories were more likely to have more complete life skill training. Several workers referred to the emotional need of the youth as requiring time and attention before transitional planning and life skills development could occur. Yet despite this need, time limits associated with facility mandates, Provincial licensure and care agreements acted as barriers to life skill development as other needs took precedence.

We used to focus more on the older youth and the ones that were gearing towards independent living but I think our focus now is going to be just learning those skills earlier. The thought being that you are never too young to learn the skills and they will be skills that they'll be able to develop for longer periods of time so they'll be more equipped to be able to handle that when they move out.

The creation of a life skills continuum among the youth care facilities was identified as a focus area to further nutritional competency development.

A program of some nature that the kids could participate in, whether it was over so many weeks or whatever sort of thing. When we know the young person has a discharge date of such and such a time that they sort of strongly be encouraged to participate in this kind of graduated program. So when you're done you're gonna be ready; you're gonna know what's at the other end a little bit more anyway and feel a little bit more confident if you're in a semi-supervised apartment or living at [locale] that once a week you're going to have to prepare a meal.

The planning and implementation of this approach would require program changes within the youth care facilities serving younger youth. Overall, the youth and youth care workers concurred that mandating life skills programs was ineffective; however, restrictions with discharge timelines necessitated this approach. Within the Child Welfare System, government policies that define sixteen as the age of a child “in need of protection” (1) impact the development of nutritional competence and transitional outcomes. Youth care organizations are forced to accelerate life skill training and youth are rushed to master the skills because these policies drastically shorten the time frame for them to become responsible and self-reliant. Depending on the nature of the care agreement, custodial services can be extended to eighteen however this is still out of sequence with common transitional trends as reported in the literature. (4)

The age dependent policies also contribute to the anxiety related to transition (21) as time pressures complicate the ability to become transition ready. In addition to learning life skills, many youth require time to address the emotional context and personal meaning of transition. Societal values of autonomy and self-sufficiency seem to influence the policies that define milestones by age as opposed to ability. Youth exiting custodial care at an early age are more likely to experience undesirable transitional outcomes, such as homelessness, food insecurity and low employability.

5.3. Personal Influences to Nutritional Competency Development

Personal traits of resiliency, determination and life experience greatly influenced nutritional competency development. Youth with extended placements in one facility were considered more likely to develop transitional life skills. The following comment by a youth care worker suggests that extended periods of stability aligned with increased learning opportunities.

Basically the longer they're here, the more time they've had to really learn a lot of this stuff.

Another youth worker mentioned the young persons' interest, aptitude or 'buy-in' to learn life skills as an important determinant of successful transition

(VB): So at the end of the day do you feel that they're ready for transition to independence?

You know, yes and no. It depends on the youth. It depends on what we had for success with goals and stuff. Some youth buy-in very well and we've also had some youth that don't buy-in. They just don't want that; they feel that they're independent from the beginning.

Conversely, two youth participants spoke of a personal determination to be self-reliant. They purposely distanced themselves from any expectations of others including youth care workers and social workers. As such, they did not "buy-in" to the facilities' programs because they considered themselves ready for independence.

I didn't really want to listen to anything anybody said. I wanted to try and do everything on my own...

I kinda did my own thing. I wasn't really trying to be involved in the program. I was doing it my way.

The childhood experiences of some participants precipitated an early introduction to life skill development through necessity rather than desire. Food related life skills were acquired through exposure to activities such as accessing food through charitable organizations, preparing food for younger siblings and working odd jobs or collecting bottles to provide food. These early

experiences laid the foundation for transition, as these youth were resilient and well versed in street survival.

Self-taught I guess you could say; experience, cause half my life I was on my own.

I learned a lot of these things growing up, right. Even before like, before going into the group homes. I kinda grew up in a difficult environment where I had to learn a lot of these things. So, I kind of, I grew up when I didn't have, when I shouldn't grown up. At that time, like I was a kid.

Youth engagement was dependent on the perceived relevance and the meaning attached to the life skills program. Some youth participants indicated they were not ready to begin planning for transition because they believed there was plenty of time. Thereby, transition preparation was considered secondary to other priorities.

Well now, I know that I needed them but then, it was just, that's a waste of time

A lot of youth care staff have the best intentions in the world but its always who you're trying to teach; who are you pitching the information to? That's the biggest problem, can they receive the information, do they want to hear it or, you know, do they want to do what they want to do?

It is common for young people in custodial care to have mixed emotions regarding transition; experience has taught them that transition is associated with loss and uncertainty. (21)
The meaning attached to transition can have a positive or negative influence on the planning and

preparation process. The importance of addressing the youth's emotional needs was recognized by several youth care workers; as reflected in the following comments:

Sometimes I find it is a lot of their emotional needs because they hide a lot of that. I find emotionally, like they can be laughing and carrying on but inside they're really not letting go of what's really on their plate. I find that we really got to look. We don't see it.

You know, their needs are not always physical.

Most of them, even though they are chronologically sixteen or seventeen, they've had a lot of experiences in their lives but its not necessarily positive experiences. They have a lot of doubt and most of them don't trust people very easily or very well; or over trust, I suppose, on the other hand. They're supposed to be adults by the time they're sixteen, able to make decisions for themselves but based on, you know, life experiences and living in group care settings and that sort of thing, they're not prepared at sixteen to be making decisions.

These comments would suggest that the transitional process requires a holistic approach that includes a focus on emotional needs in addition to life skill development.

5.4 External Influences on Nutritional Competency Development

The external influences refer to people, services and supports outside of the youth care facility environment that impacted nutritional competency development. This delineation is not meant to imply that these influences were removed from the youth's everyday experience; rather it is simply an easy way to isolate the youth care environmental influences from others.

5.4.1 Social Worker

In some cases, the social worker represents one of the few constants in the young person's custodial care experience. The youth participants were split in terms of the significance the social worker had in their life skills development and transitional experience.

(VB): Were there any supports you found helpful when you were planning to move out on your own?

Ummm, my social worker actually, my last social worker, she was a big help.

Youth care workers suggested that social workers were often unsure of the care plan direction in relation to life skills development. Mainly life skill development decisions are determined by the youth care team and the young person simply because the social worker is not part of the youth's daily environment and routine. The following comment by one youth care worker provides an example of a social worker's sweeping approach to transition preparation:

So at the time of admission we usually get a sense of where the social workers would want the youth to go and we try to gear up around what we can help be. Most times kids get here and the social worker just wants them to learn independent skills... independent life skills and we're like, oh, OK

The social worker role did have a significant influence on nutritional competency development in terms of provision of financial support for life skills programs.

We had to rely on the Agency to provide extra funding so that we could allow this young person to have their own groceries.

The ability of social workers to support individualized life skills programs and participation in community groups or classes are bounded by budget constraints within the Department of Community Services. In theory, the social worker may be supportive of innovative ideas to nutritional competency development; however, this does not presuppose that the approach can be supported financially.

5.4.2 Financial Restraints

Youth care facility financial parameters not only influenced the facility operations but also impeded the development and sustainability of life skills training programs. As stated by one youth care worker, previous attempts to provide life skills programs were short-lived due to money restraints within the youth care facility budget.

I know when we did have a more structured life skills programming around food preparation and budgeting and grocery shopping, it becomes a financial issue. Because you know, we have a particular budget for our food budget and having young people go out, prepare a meal and take that money out of our food budget can oftentimes be very expensive

The need for increased financial support was identified as one way to improve transitional outcomes within the youth care milieu. One respondent felt that increases to the facility food budget would allow for an expansion of the life skills program.

If we had more money in our food budget, an increase in our food budget we could do more and probably a better job 'cause you could do some different things.

5.4.3 Community Resources

Participation in community groups or classes external to the facility also influenced development of nutritional competency. The resources identified by youth care workers included cooking classes, grocery store tours and guest speakers. One facility representative spoke of the efforts by youth care workers to research various community programs that would meet a particular need or interest.

That's one of the things about planning; we try to find what's out there for the youth. We have program planning here so they have to look out and find resources to help the youth in whatever areas.

However, one youth care worker was more cautious in the use of external resources,

...I know that there are, umm you know, Sobey's and Superstore do their cooking you know, weekly, bi-weekly whatever it is, classes and that sort of stuff that sound really good but these youth aren't really sort of the typical young people that are going to be able to slide in with a group.

Some of these external resources required special funding that was not always available. The ability of social workers to financially support the use of external resources is often limited by budget constraints. Additionally youth care associations are usually 'not for profit' and as such operate under strict monetary allowances making extras such as life skills programs unattainable.

Many of the community programs are modeled for middle class, food secure individuals and may not be relevant to this population group. Basic cooking and food safety knowledge may be gained, however these classes may perpetuate a false sense of post transition nutritional

capacity among the youth. In essence, the type of food and necessary equipment may be beyond the youths' post transition food budget.

5.4.4. School System

The school system was identified as an important influence on the youths' nutritional competency development. This was an unexpected result in light of the literature (3,12,14, 32) reporting the prevalence of disrupted school histories of youth 'in care'. Several youth viewed the education system as a forum for learning life skills in addition to academic instruction.

Most exposure to food related skills in the school system occurred in junior high but the youth felt that extending this to high school would be helpful.

I took a cooking class in like junior high; that would be the only food related class. They should have them in high school and stuff really; definitely helped to like learn things.

One youth care worker suggested that the education system consider a course in nutrition for all students.

Well, there's the little things, like they could use the school system. There are some types of courses but they're not mandatory. So yeah, even if they had one mandatory course outlining nutrition, I think that would help a world of people, you know and not just here but everywhere

The school system is positioned to act as a transitional support that provides continuity between custodial care and independence. The school system is positioned to act as a transitional support that provides continuity between custodial care and independence. Presently, school district policies and movement between them are such that a move out of district necessitates a

change in school. These policies do not consider the unique needs of the youth in custodial care, who are often faced with moves that are beyond their control. A transition between youth care facilities in an effort to better meet the needs of the young person, ought not to be defined by a change in school. This unnecessary disruption can negatively impact a young person's academic achievements and represent a loss of a support system.

The association of the school system with the youths' nutritional competency development would imply that increasing the scope of life skills programs is worthy of further study. In light of educational cut backs, creative cost effective approaches, such as job shadowing and volunteering within school food service areas may be considered.

5.5. Social Influence on Nutritional Competency Development

Gender socialization with food related skills and nutrition knowledge was identified as having a negative influence on the delivery and acceptance of life skills programs. As noted by one worker the prevalence of female headed and female led households perpetuates the notion among male youth that women are responsible for food related activities. As a result, male youth are less interested in learning nutrition related activities unless presented as a voluntary, fun engagement.

(VB): How do you think the young people fare in terms of nutritional competency once they're out on their own, in your experience?

I don't think it's great. Ummm especially boys, as much as we try not to you know, make the stigma of female in the kitchen, we have many men cooking here as we do females, umm I don't think the interest level is the same for a lot of boys as it is for girls in terms of spending time in the kitchen. I just don't see the interest there

the same at all nor do I see them inquiring or being curious unless we draw them in.

Conversely, another male facility voiced a different experience in that the male youth enjoyed the nutritional competency component of the program. While gender bias was raised as an issue by facility managers, this difference in interest in food skills was not apparent in the youth interviews suggesting discord in opinion regarding gender as a factor in nutritional competency development

5.6 Summary

The development of nutritional competency was not influenced by a single person, program, approach or event rather this knowledge was shaped by a composite of influences that extended beyond the youth care environment. Some of these influences were within the participants' control while others were not. Within the various spheres of influence, the participants shared barriers and enablers that impact the planning and execution of nutritional competency development. These influences and subsequent areas for change extend beyond the youth care facility environment, to include academic institutions, government policy and societal ideologies

The task of preparing youth to move out on their own was an onerous one in the best of times and best of circumstance. For those who work within community based group care facilities, the transitional process was daunting because individual needs were highly variable and available supports limited. Yet, in spite of it all, it was acknowledged that varying degrees of nutritional competency development was realized within residential group care environment. The question then becomes, can the nutritional competency be applied once transition occurs?

CHAPTER VI: RESULTS and DISCUSSION II: TRANSITIONAL OUTCOMES

6.1 Introduction

This chapter will explore the participants' transitional outcomes with respect to nutritional competence and food security. While the process of transitional preparation within the youth care milieu required a retrospective approach, the transitional outcomes as determined through data analysis are present-focused. The youths' nutritional competency is discussed in the context of two themes: *Transitional Outcomes and Food Insecurity*. The experiences and perceptions of transition, as shared by representatives of youth care facilities will be discussed in tandem with the youth participants' responses. This section will conclude with the youth participants' advice to their counterparts who have yet to traverse from congregate care facilities to independence.

6.2 Transitional Outcomes

Youth perception of and reaction to the transitional process varied with the individual. Despite difference in preparation, life skills training, monetary resources, social support systems and self-efficacy, the youth concurred that the transitional phase was a challenge. The capacity to apply nutritional competency was influenced by several post transitional outcomes. These outcomes included: *Transitional Adjustment, Incomplete Life Skills Knowledge, Isolation, Poverty and Homelessness*.

Mapping of Transitional Outcomes

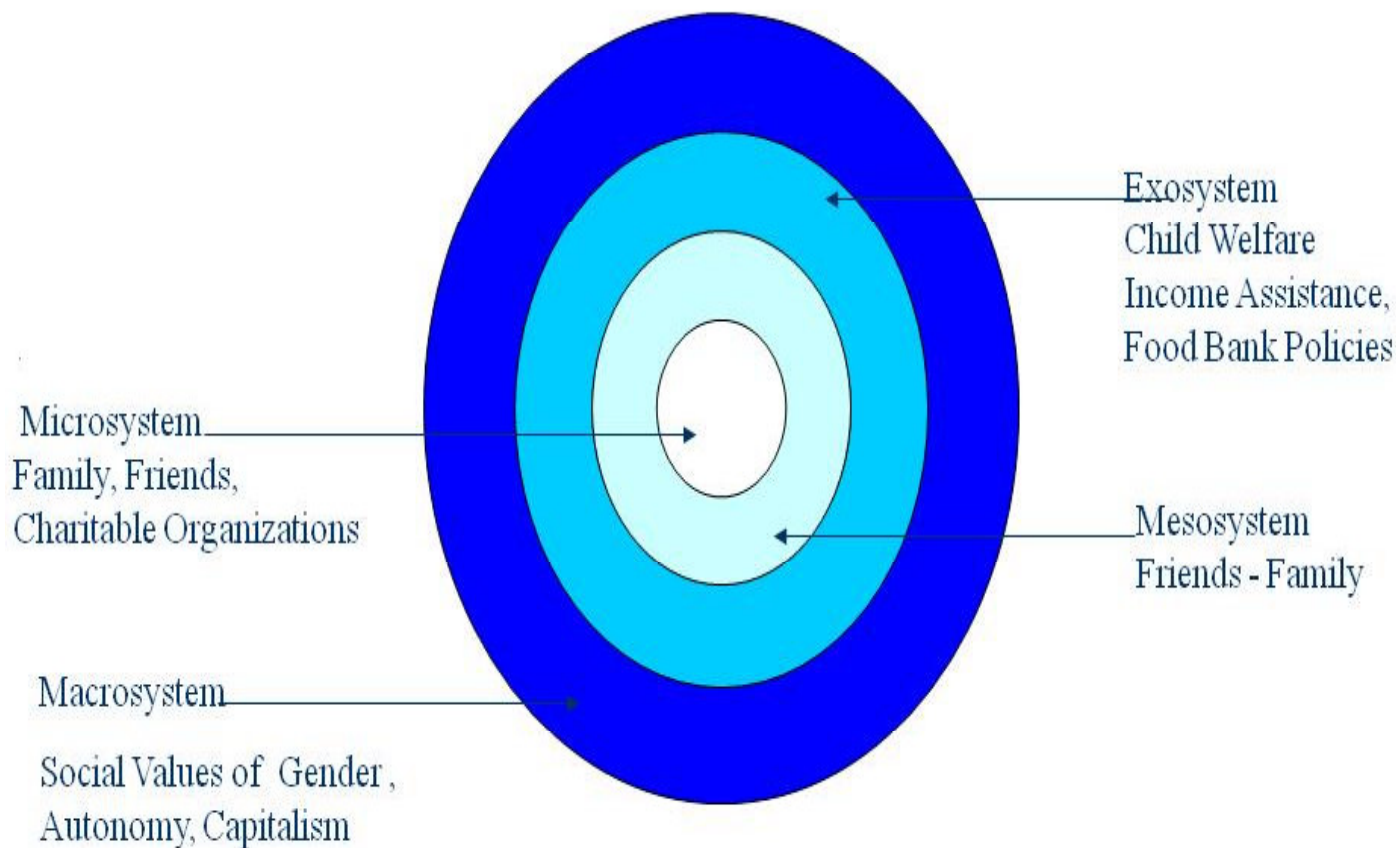

Figure 3 Transitional Outcomes

6.2.1. Transitional Adjustment

As depicted in Figure 3, the abruptness of leaving child welfare care was marked by a shift in the youths' everyday relations and environment. The youth care workers were no longer present to guide their daily activities and for some there were no family members or significant others to provide needed support. Transition also marked a change in or termination of the youth-social worker relationship. For youth with extensive histories in Child Welfare Care, the youth-social worker relationship could span years thereby making its redefinition or termination particularly difficult.

Several youth referred to the abruptness of leaving child welfare care and thereby expressed feeling unprepared for the transition.

(VB): So when you were in group care and planning on moving out on your own were there any supports that you found helpful?

They kicked me out so I had no choice; you are either out or I could choose to go to another group home or, ummm and I was like, no, I don't want to stay in group home no more. I want to explore. I want to be on my own.

I knew I had to be ready so I kind of just went with the flow but it was a little stressful, in terms of just, you know, it kinda felt like a drop off point

I don't think anybody's ready really for their first apartment. You walk in and yeah it's an overwhelming feeling really. You walk in, you look and you're like Oh my God I need this, I need to get that, I need to make a list; it kinda gets overwhelming.

Discharges that were unplanned had a negative impact on the young person's capacity to apply their nutritional competency. One youth participant shared the following transitional experience:

I didn't have pots and pans; I pretty much cooked everything via microwave

The lack of equipment to realize food competencies was a challenge for some respondents. Typically, these items are purchased with money distributed by the social worker. In the case of premature discharge for non-compliance, the youth would have neither the time nor money to acquire the basic essentials to set up a household kitchen. Moreover, these items would be considered secondary to critical needs such as shelter and food.

Some youth shared their transitional adjustment to being on their own without rules and having freedom to make their own decisions. These experiences are contrary to the youth care environment whereby facility rules and operational policies guide the youths' actions, restricts freedom and limits choice. This adjustment is illuminated by the following comment:

It was weird being so much free. I didn't have so many rules and not even rules, just like, I didn't have a curfew, I didn't have this, I didn't have that. So that was weird because I was able to go and do everything I wanted.

The youths' struggles with freedom, self-regulation and organization point to a lack of preparation and familiarity with decision-making, time management and problem solving. This suggests that the youth care facilities and their operational policies were not conducive to the development of these skills.

The youth care workers made reference to the emotional challenges for youth as they moved into an adult system of service provision; many youth were neither considered

emotionally nor socially prepared to navigate this system. Moreover, the emotional investment related to transition was opined to contribute to the struggle.

It is a culture shock to them when they get out there

It's just a shock; them trying to muddle their way through all these learning experiences, as they're doing it and that's probably not the best way to throw these sixteen and seventeen year old kids into the real world.

They know they don't want to be here but they don't know where they want to be. Particularly around sixteen that's a pretty volatile age in the best of times and the best of conditions. Very, very difficult for these kids to think about; they have fear of the unknown; fear of what am I getting into. The bulk of these kids at age sixteen are not going back home.

Often the experience of leaving custodial care is associated with uncertainty, indecision and resistance. In a time when the youths' social relations are being redefined, the lack of life skills and emotional insecurity make the transition process especially daunting.

6.2.2. Incomplete Life Skills

The life skills program experiences of the youth respondents were varied. Most nutritional competencies were developed piecemeal and complementary food related skills were lacking at time of discharge. The transitional challenge as shared by one youth highlights the outcomes of life skills programs that are not comprehensive in approach. This youth acknowledged an ability to cook however inexperience with budgeting and food purchasing had precipitated a pattern of eating out.

The whole problem is with the grocery store and knowing what to get. Just going to the grocery store that's the whole problem I guess.

VB): So what is your strategy in meeting your food and nutrition needs?

Well like fast food, restaurants, mostly. Ummm I buy groceries sometimes but it seems like when I buy groceries, its crap anyways.

Struggles with time management skills were evident throughout the youth interviews. This would point toward a lack of opportunity to develop this skill within the group care environment. In terms of transition, several participants indicated a sense of urgency to learn all the necessary life skills and strategies to address transitional concerns and challenges: *You either learn or you don't learn; but you have to learn quickly.*

The lack time management skills was mentioned in relation to the application of nutritional competencies such as cooking meals at home, preparing grocery lists, meal plans and grocery shopping. When asked what the greatest challenge has been since moving out from group care, one respondent replied,

Umm, making sure I actually go to the grocery store and buy groceries rather than eating out, cause I eat out. Basically, all my meals are from fast food or whatever. I don't buy groceries; I haven't bought groceries since I got home from school. I don't know. It's time consuming.

Another respondent, when asked about specific challenges related to food and nutrition, spoke of the time in preparing and planning healthy food.

Finding the time to eat healthy.

(VB): Oh, ok

It's a lot of preparation. Like if you're making meat and potatoes type of supper, so meat and potatoes. You got you peel the potatoes and cook them; then you gotta cook your chicken or sausage or whatever you are making with it. And it takes a bit of planning too cause if you're making something frozen, you got to take it out and if you're working and you don't take it out, then you got to go home and unfreeze it then eat supper at 10:00 o'clock

6.2.3. Isolation

The adjustment to independence was marked by periods of isolation for several of the youth and building a supportive network was an important part of achieving success. For many, transition marked the revival of family relations, whereas others looked to friends, community-based organizations or romantic partners for support.

In response to a question assessing the youth's level of readiness, one respondent commented:

I think it was pretty smooth but I got lucky though where I had a boyfriend and a roommate, I didn't have to pay rent right off the bat so I got eased into it.

Another youth, in response to a question regarding approach to transition replied:

I started to build my own resources in (locale). So instead of like where before if there was an issue or I didn't know what to do about something, I would run over to (locale), but I couldn't do

that in (locale) so I had to learn to do things on my own. So I started to build my own resources and my own social network.

With respect to family, several youth indicated that these relationships helped them access food. Some youth specified that although they went to family for support on occasion they did not make it a habit.

I don't get into the habit of asking them for everything 'cause you don't want to be a burden on your family

But yeah there's a couple of times you get lazy or whatever for a few days so you take a shot up to your cousins and eat his fridge out.

Since transition, most youth acknowledged increased family contact.

Now I go to my mom's house every weekend and get stuff over there.

(VB): What about family, have you gone to family for support.

Yeah, sometimes

(VB): Is that something you did while you were living in group care?

No, not really

Reunion and revived relationships with family members was identified as a common transitional occurrence. While the impact of these relationships on transitional outcomes was beyond the scope of this study, these family support systems would be potential influences within the youths' microcosm and by extension provide emotional, financial, educational

support. It was one youth care workers' experience that, in spite of difficult family histories and prolonged separations, efforts to revive these relationships were common after discharge.

(VB): Has it been your experience that the youth will move to their hometown or closer to family?

It's very interesting when you're in the youth care field. Ultimately they could come from the worst situation but its family. It's unfortunate sometimes you see that, you know, there's limitations and I understand there's really good reasons why there's limitations or supervised visits or access visits and different things like that but ultimately they're going to hook back up...They do, all, ummm, for most of our youth, experience is they go home or a relative or you know, Mom or Dad.

Adjustment to isolation was a common transitional challenge among the youth participants. In consideration of the drastic change in their everyday environment and support systems, one can begin to understand that issues of loneliness and isolation would come to define their transitional experience. Episodes of isolation influenced the youths' capacity to apply their nutritional competency in that they no longer had support from another source to guide their daily activities:

Hard really hard cause I was so used to everything being structured and when you move out on your own it's a lot harder because there's no one there making meals for you, there's no one there telling you when you need to be home, what you need to do, so it was a lot different.

Isolation as a transitional outcome is not surprising in light of the changes in the youths' social relations. The Bronfenbrenner framework (56) as shown in Figure 2 and 3, illuminates the dichotomy of custodial care and post transition social relations. The shift in relations is extreme, especially for youth who did not build transitional support systems prior to exiting custodial care. In the absence of a support system beyond the youth care environment, it is likely that these youth will experience loneliness and isolation following discharge until they are able to form new relationships or revive others.

Interdependency is a key term that refers to a paradigm shift from promoting autonomy to building relationships with family, friends and community to meet the youth's need while in custodial care and following transition. (19) The adoption of this philosophy within the Child Welfare System could help bridge some of the gaps that exist between the social relations of custodial care and independence. In essence, the change is made less drastic by the presence of a support system that continues regardless of 'care' status.

6.2.4 Poverty

All respondents indicated experiencing trouble with money management and budgeting and, in some cases, this challenge existed despite money management experience while 'in care'. This calls to question whether it is a matter of poor financial management, inadequate life skill preparation or indication of a near impossible task to meet basic needs because of inadequate monetary support.

When asked about specific transitional challenges themes of money and budgeting were common, as evidenced in the following comments:

I found the budgeting points with money and all that stuff was hard; like I wasn't taught how to budget, nothing so I found that was hard. Still learning!

Overcoming the urge to waste money and make your money last a whole month

In accordance with the tendency for youth in care to 'graduate' into an alternative social support system following discharge from custodial care (12), the majority named income assistance as their income support. (Figure 3) Social assistance policies marked by inadequate income mediated struggles with food insecurity and impacted the nutritional competency of youth involved with this study. This finding aligns with earlier studies (36, 67) in that social assistance as a source of income had a negative impact on nutritional needs and an increased likelihood of food bank use. (68) The youth could not afford to purchase a nutritious food basket (47) and internalized these struggles as evidence of their inability to budget. However, it would appear that their level of nutritional competence was inconsequential because they simply did not have enough money to make ends meet.

Without exception, the youth were unanimous in identifying money as a mediator to the improvement of transitional outcomes. Mostly, the youth named the government as responsible for increasing financial support to vulnerable individuals and the programs designed to help them.

It's like a big, big problem, you guys are facing because you guys got to deal with food bank issues. You know, the government needs to hand out more money to the people, but they don't want to do that. They want all the billions for themselves. Then they leave people working in facilities that are all basically falling down around themselves; programs that don't work, you know;

funding that you don't really have. So umm there's a lot of problems that need to be fixed up, right.

The Social Assistance policy is rooted in social ideologies of autonomy and self-sufficiency. Section 2.13 of the manual states that “the clients must have the knowledge that their benefits will provide the supports necessary to move towards self-sufficiency.” (69) For youth leaving child welfare care, they are expected to move towards self-sufficiency and yet life experience has left them ill prepared to do so (10)

6.2.4.1. Youth Care Menu Practices as Financially Unsustainable

The financial challenges permeated the youths' ability to mirror eating practices as experienced within the youth care facility milieu. This outcome is symbolic of a double edged sword, in that, several youth respondents credited the facilities' menu patterns for teaching healthy, balanced eating yet, once on their own, they could no longer model the eating behavior to which they had grown accustomed.

It's really hard; don't have enough money especially being on social assistance. So you get \$200 personal allowance and you get there and try to get the food you want but it's not going to really do anything cause you have to work with just what you have.

Some things here and there but like you know nothing like chicken, let's say. It's so expensive. We always had a lot of chicken in the group homes. Yeah and milk too, an unlimited supply of milk in the group homes but like that's quite the price, too.

In general and without attempt to maintain previous eating patterns as experienced 'in care', several youth participants stated that eating healthy was not affordable on their restricted budgets.

(VB): So when we talk about food and nutrition what have you found to be most challenging since living out on your own?

Umm. Getting the nutrition part. Like I can't afford to buy, a lot of eggs and stuff like that and have salads all the time. Me, I'm picky about my vegetables; some I want this way and some I want that way. It gets expensive 'cause frozen vegetables and like canned vegetables are a lot cheaper but I won't eat them. I have to eat my raw fresh vegetables and that's expensive

The recognition of facility menus as a learning medium for healthy eating provided an example of the imposition of middle-class values and experience on the youth. These patterns of eating were not sustainable and thereby, did not consider the relevance to young person's transitional social context. This relates back to the organization policies and youth care workers' influence on menu development. For some facilities, menus did not align with the transitional realities of the youth participants. This is an area for future consideration.

The menu practices within the youth care milieu presents as an interesting ethical debate in terms of food security and nutrition knowledge. At one end, there is the positive outcome that the youth are being properly nourished during a time when their growth and nutritional needs are significant. This, coupled with the knowledge gained regarding healthy balanced eating can make a solid argument for upholding the status quo.

Conversely, it can be argued that the youth are being set up to fail. For many, inadequate income will mediate the youths' inability to mirror these eating practices and by extension, foster

a sense of guilt and inadequacy for failing to live up to a standard (51) rooted in the middle class values of youth care organizations and those that work within them.

6.2.5. Homelessness

Three participants shared experiences of homelessness and sheltered living. This aligned with the results of another study (35) reporting the disproportionate representation of former youth in care among the homeless. When asked about their transitional experience from group care, two respondents did not have a place to live at time of discharge.

(VB): can you tell me a bit about moving out on your own?

Ummm, really hard to find a place to sleep. I don't really do the (locale) thing 'cause it's pretty gross down there. Other than that, getting woken up at 6 o'clock in the morning by police telling you to move along. It wasn't too hard.

Yeah, there were friends that let me crash at their house. Stuff like that but most of the time I was on the street. I spent a lot of time in the woods, living there.

Clearly, homelessness was a negative influence on the youths' capacity to apply nutritional competency and by extension contributed to food insecurity. (31, 6) It appeared that an abrupt unplanned exit from custodial care was a strong indicator for homelessness.

The age of minority defined as 16, (1) sets forth the possibility for the care agencies to end services out of fear of liability. Alternatively, this policy enables youth who want independence to follow this pursuit even though they have not been prepared. Regardless of the manner of exit, this policy results in the termination of services for young people who are ill

equipped to navigate the adult system due to low employability; low educational attainment and limited life skill development. Clearly, homelessness was a negative influence on the youths' capacity to apply nutritional competency and was a strong marker for food insecurity. .

6.3 Food Insecurity and Transition

The results of the HFSSM, as supported by the literature, (14) indicated that food insecurity was common among the youth participants; four of seven were moderately food insecure and three were experiencing severe food insecurity. The youth with jobs scored lowest on the questionnaire nevertheless, they were still determined to be moderately food insecure based on scoring standards of this tool. The youth who had unplanned discharges were considered severely food insecure, thereby accentuating the difficulty of inherent to abrupt transitions.

Inadequate monetary support was cited most often as the primary contributor to food insecurity. The prevalence of food insecurity among the participants would suggest that changes in their social relations were so profound, that it impaired their capacity to apply life skills training and nutritional competency. The struggles with food insecurity are illuminated by the following comments:

I just make enough money to support myself working full time

The money goes and you still have no food

The Government and people that give you that nonsense that there's a food crisis, now all the prices gotta go up but we ain't giving you no more money.

The most difficult thing...they don't give you a lot of money to work with, like I said I can't eat healthy all the time and a lot of the cheap, cheap food is really disgusting. One of the challenging things is to try and find your proper meal because again, you can eat one meal a day that's fine, but you really should have a couple of them a day.

The concept of food security is a complicated, multifaceted issue; subject to multiple perspectives affecting all levels of the social strata, from the individual to the universal. Among the many strategies to assuage food insecurity, food bank use was most common.

Many of the youth care facility representatives held the view that transitioned youth; most notably those receiving income assistance support, struggled to meet their basic food and personal needs. This standpoint concurred with the recent NS participatory food-costing data indicating that a single recipient of income assistance was unable to afford a nutritious food basket. (47) In response to a question whether the facility ever received feedback from youth who had lived in the facility, one youth care worker shared the following comment:

Yeah, certainly we get a lot of phone calls around youth needing to come by and have a good meal as they put it. Umm, because they are out there trying to struggle with a very low budget, once they're out there and what they're finding is that they don't have enough money, they don't have the skill sets to prepare enough meals for a week or prepare meals ahead of time, that kind of thing.

The financial restrictions were further compounded by what respondents referred to as a lack of skills, knowledge and awareness to compensate for the lack of monetary resources.

6.3.1 Food Bank Use and Transition

The majority of youth had used food banks since their transition from custodial care, a behaviour that is indicative of food insecurity. (53) In describing experiences with food banks, the youth participants stated that generally the food available did not meet their needs and the procedure of food procurement based on 'first come first served', required time and planning to get the best food choices.

As long as you don't mind getting up at 6 o'clock in the morning because they open at 9 but by 8 o'clock there's typically a line up of about 40 people. You gotta get there early cause usually there's lots of times when like number 20 or 30 comes along and there's like only canned food left.

The policies of food banks and their donor-reliant characterization had a cascading effect on the nutritional competency and food security of the youth. In accordance with other reports, (30, 46, 50, 70) the ability of food banks to ensure food quality and quantity is uncertain, thereby nutritional needs are not met with this resource. Despite best intentions, the structure of charitable food organizations is such that the individual has limited power over their food choices. This was evident in the words of one youth who described the experience of visiting the food bank and being offered various types of sugar.

When it gets to you, you want to go to the food bank and they give you all kinds of, you know, if you want puddings and sugar. You want icing sugar and brown sugar, you know, you want syrup...like no man!

The deficiencies of donor-reliant charitable food organizations compromise dignity and nutritional status. The youth relying on this resource are forced to take what is given regardless of taste preference, cooking abilities, extent of need and product quality.

6.3.2 Approaches to Meet Nutritional Needs

Much of the literature exploring the outcomes of transition of former youth in care can be defined as an identification of the gaps and short falls within the transition journey. While it is important to recognize the barriers to successful transition, it is equally imperative to acknowledge the resiliency and determination of the youth struggling with this phase in their social and emotional development.

6.3.2.1. Self reliance

Many of the youth participants demonstrated a sense of self-reliance in terms of post transitional learning. Although they recognized the struggle, many expressed determination to find their own way. Arguably these characteristics of self-reliance can be deemed evidence that given sufficient support, access to resources and time, the youth can make a successful transition from child welfare care to independence in sequence with the move from youth to adult.

*I can make an effort on my own self, for myself to get what I need
so I don't have to be a burden on anybody else*

*...When you're cooking, you learn or not even just cooking but
when you're grocery shopping, you learn. It's all a learning
experience really. The best way to learn is to do it on your own, I
think.*

*I got taught a few things but mostly it's been just learn as you go.
Sometimes that's the best way to learn things.*

6.3.2.2 Strategies

Expanding on the themes of self-reliance and self-efficacy, the youth respondents had adopted a variety of strategies to help meet their nutritional needs. Although certainly not an exhaustive list, the youth participants shared strategies that were pragmatic, resourceful and effective. Some planning strategies included making meal plans, grocery lists, visiting the store to check for sales, and cooking large batches of food and freezing. Additional strategies were buying bulk and No Name products, using leftovers, coupons and remembering prices. Finally, several youth were active in seeking out community resources that could help them build upon their life skills knowledge.

The following comments will highlight some of the strategies adopted by the young people to meet their nutritional needs:

Sometimes I'll make like a family pack of Hamburger Helper and umm just make it all up and then have it one night and just have the same meal again the next night. It's the same thing but it's all good, still getting a meal, still getting food.

Well I make sure I get what I paid for. Like I don't ummm, I'm not going to buy like, sometimes lean hamburger, it comes in little bitty packages and it's still five bucks. No I rather buy medium hamburger and have to drain it off three times and save money and get more.

One youth adopted the habit of buying the same groceries to ensure that there was enough money in the budget.

I usually just buy the same things I need and never go to the grocery store when you're hungry.

6.3.2.3 Resources

The majority of youth (and youth care facility representatives) identified Phoenix Youth Programs, specifically Phoenix Center as a vital post-transition resource. The mandate to serve youth until 24 years of age positions Phoenix Youth Programs as being one of the few resources available to transitioned youth.

Well Phoenix Center was always helpful; there was always food there. There was always someone there you could talk to if you needed somebody to; always showers.

In terms of food and nutrition several youth spoke of their participation in a cooking program offered through Phoenix Youth Programs. One description refers to the many benefits:

I go to a cooking program now with Phoenix Center. Ahh, we met at 4 o'clock, we have a grocery list of what we need to make what were going to eat and we go grocery shopping and we go cook it. It teaches you on how to work within the budget of how much money you got to work with...And if you don't go then you're not going to learn. So yeah, you have to try and learn things. I mean you can learn it on your own but that takes awhile.

(VB): So what do you like about the program?

Well it's fun and I experience new ways of cooking. It just gives me a wider knowledge of views and what I can cook and how I can do it.

Several resources such as soup kitchens, resource centers, supper churches and youth care facilities were mentioned; however, their prominence waned with time as the youth gained a more secure footing with their independence. This finding was testament to the resiliency of the youth as they journeyed through this significant transitional phase.

Three youth indicated that they use the computer to find nutrition information, answers to questions or recipes. This finding implies that this medium may prove to be a valuable tool in transition planning and after care support services.

I have a computer so any recipes I want I look up on-line.

I have a recipe book though that I've copied from on-line. I've used a couple of them

Two participants suggested that a booklet set up like a how to guide would be beneficial. When asked if they were familiar with a street survival guide distributed by the Phoenix Youth Program in 1992, they replied that they were not aware of this resource. This medium would have the potential to reach out to those youth who did not have the opportunity or interest to learn life skills regardless of the reason.

A street survival guide would help.

If you have some type of, ummm, if you know what I mean, a booklet type of thing with budgeting, how to grocery shop; something like that would help. Like more information than there is now.

6.4 Advice for Youth

The youth respondents had several words of advice for those currently residing in child welfare care irrespective of plans and timelines for transition.

As was the theme throughout, the youth participants emphasized the need to learn budgeting skills. This was the most common response when asked what advice they would share. It evokes a sense that the youth are internalizing their financial challenges as something within their control whereas inadequate monetary support and incomplete skills development may be a more fitting answer. This sentiment seemed to convey a hope that if you try hard enough you can budget away the challenges of transition.

...save up your money; especially saving up money, you're gonna need it when you leave.

Take a look at the budget as to how much you're going to spend on each one and before you go to the grocery store plan out what you want to eat that week.

Reflecting on their experiences and the resources available while residing in the group care environment, most youth participants expressed regret they did not take advantage of life skills programs and other opportunities. Several indicated that their optimistic outlook on independence was misguided and as a result, their transitional challenges were heightened.

Try to take it serious because it's gonna be difficult either way when you're out there...

Not rush into it, I guess. Take all the help you can get; anything that's offered to you that would help you in that sense and do it, especially budgeting plans are a big one.

Ask a lot of questions and stop taking the services like the food that the group homes get, for granted cause once you're gone, you'll realize a day where there is no food.

Finally, other youth respondents' offered practical advice related to nutritional competency.

Try not to get into the pattern where you eat out all the time and try to get in the good habit of buying groceries and just making food at home.

And use leftovers and freeze spaghetti sauce.

The advice offered to youth currently residing in residential group care would suggest that retrospectively the participants recognized the value of the life skill interventions. The participants encouraged youth currently 'in care' to prepare for transition by using the services and programs offered. Despite recognizing the importance of adequate preparation, the youth advised that transition would be challenging regardless due to inadequate financial and social supports.

6.5 Summary

Most participants struggled with the adjustment required to transition out of the relatively predictable and supportive youth care environment. These struggles were mediated by incomplete life skills training, changes in personal relationships and inadequate resources such as money, education and household items. Over time, the youth adjusted to their post-care environment by building support systems, accessing community resources and developing

strategies to meet their nutritional needs. Nonetheless, this period of transition was particularly difficult in terms of the capacity to apply nutritional competencies.

CHAPTER 7: CONCLUSION and RECOMMENDATIONS

Transition to independence was defined by a remarkable shift in the youths' social relations that duration and extent of transitional preparation did little to moderate. Leaving the youth care facility environment represented a departure from cupboards full of food, healthy menus, youth care worker and social worker support, financial security, and in some instances a warm place to sleep. Changes to interpersonal relationships and monetary support predicated struggles with food insecurity. Furthermore, transitional outcomes of homelessness, poverty, isolation and a general lack of life skills preparation impacted the youths' capacity to apply their nutritional competence. A comparison of the Ecological System Models (Figures 4 and 5) illuminates the dichotomy between the two environments. In summary, some nutritional competency was achieved within the youth care environment, yet transitional outcomes impeded their translation rendering them relatively inconsequential.

Mapping of Custodial Care Influences

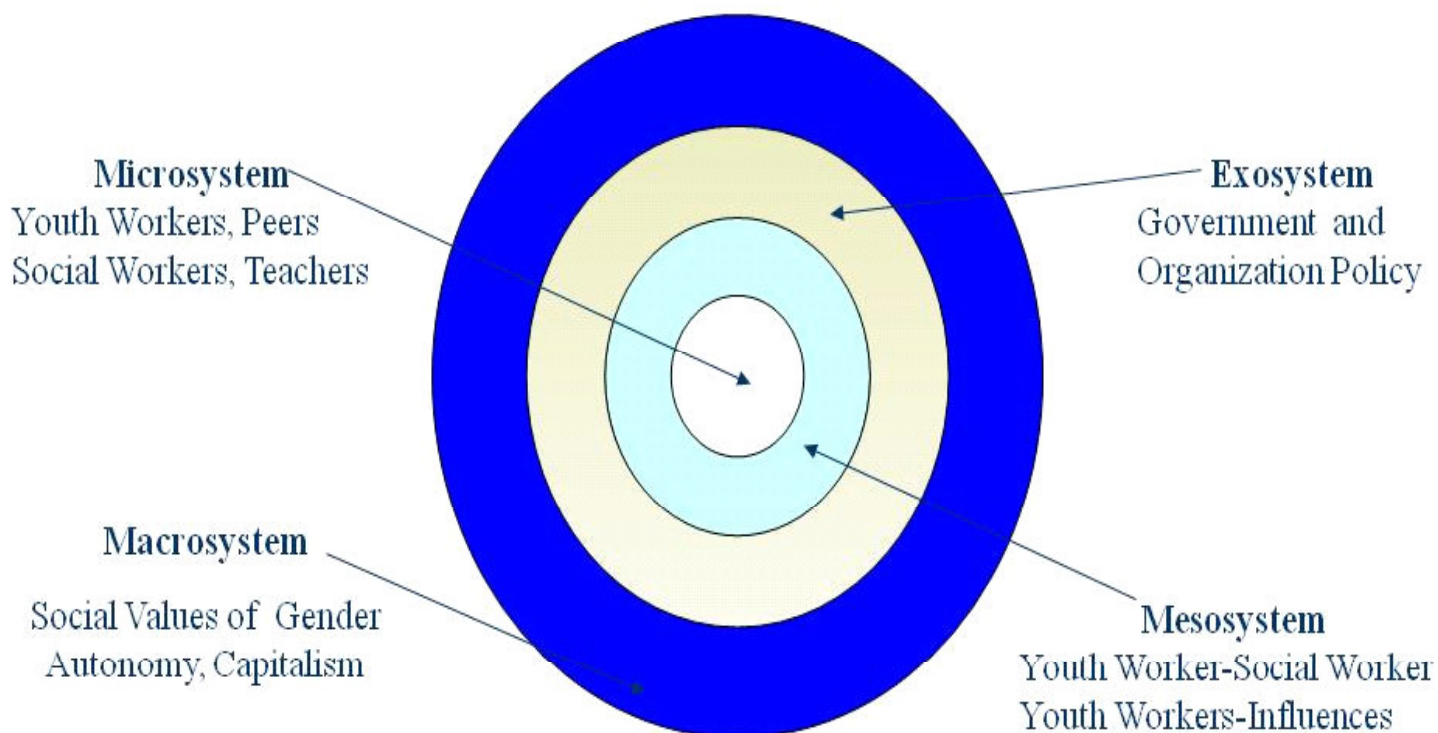

Figure 4: Custodial Care Influences Model

During custodial care placements, the youth care environment and people therein are most likely to influence nutritional competency development. (Figure 4) Within this microsystem, the youth experienced and observed various facets of nutritional competency development. Despite its promise for exacting a significant role in the youths' preparation for transition, the transitional outcomes would suggest otherwise.

The development of nutritional competency within the youth care environment was limited in scope. Complementary life skills such as decision-making, social skills and time management were compromised by facility operation or approach. Individuality was also limited by group norms that guided the facility operation. In the absence of a clearly defined process for identifying and developing life skills, the youth care facilities struggled to address each individual's needs. Moreover, evaluations of life skill programs are lacking. As such, further study is required to evaluate life skills development so that proposals calling for additional focus and funding can be supported.

The influence of the youth care team was widely acknowledged. Results of the research show that the youth care workers' knowledge and ability, as influenced by their own experiences and ideologies, had a significant impact on the youths' nutritional competency development. As shown in Figure 4, the youth care workers' social relations shape their nutrition beliefs that, in turn, influence their interactions with the youth. As noted by Garfat, (61) the youth care worker proceeds through phases in their own professional development, which in turn guides their interactions with the youth. In terms of nutritional competency development, a new youth care worker may opt to prepare meals for the youth as a sign of caring and relationship building, whereas a more seasoned worker would seek to engage the youth s' participation in a process of 'doing with' or 'doing together'.

The identification of the menus as a source of nutrition knowledge provides an example of the influence of youth care workers and facility operations. The menus were described as healthy and balanced yet unsustainable once transition occurred. This gap was one of many that existed between the youth care and independence environments. Modeling eating practices within the youth care facility to align with the youths' post transition reality, will not address the gaps in social services that create the inequalities. However, menus based on middle class values will do little to teach the youth the necessary skills and strategies required to live on social assistance and minimum wage. Therefore, in an effort to bridge the gaps in nutritional experiences between custodial care environments and independence, it is a worthwhile endeavor for youth care organizations to increase their understanding of transitional realities and consider their food related activities within this context.

As shown in Figure 4, the youth care environment was influenced by government and organizational policies that affected the youths' nutritional competency development and food experiences. While these policies guaranteed a safe and nutritious food supply, they also restricted the youths' ability to adequately prepare for transition. One example of the influence of exosystemic policies was the age limitation of "a child in need of protection" to 16. (1) This policy allowed youth to be discharged from custodial care with inadequate life skills, inadequate resources and limited supports.

The youth participants, who had unplanned discharges were particularly vulnerable to homelessness and severe food insecurity. These youth struggled to create support systems that helped their navigation and adjustment to the post-transitional environment. The finality of leaving custodial care eliminates second chances and decreases the time to practice life skills; options that are often available to other youth who are likely to stretch out their independence journey over several years. (2)

Social ideologies of autonomy and self-sufficiency are misrepresented when applied to policies affecting youth leaving custodial care. These societal values underline the development of policies that support the transition of ‘youth in care’ based on age instead of ability. As such, youth leaving custodial care are more likely to have adverse transitional experiences simply because they are pushed towards autonomy before they are ready to effectively respond to the changes in their social relations.

The youth participants struggled to apply their nutritional competencies following transition. A history of *staff doing it for you* and limited life skill training left the youth unprepared to assume these activities on their own. In light of the deconstruction and reconstruction of their social relations, few participants had a reliable support network that followed them from custodial care to independence. (Figure 4 and 5) Those who did have ‘supportive others’ were reluctant to *bother them* or *become dependent* on them. While the reason for this hesitation is not clear, it would appear that societal values of autonomy and self-sufficiency were influential.

Exosystemic relations in the form of ESIA policies (69) perpetuated poverty and food insecurity among the youth participants. (Figure 5) Post transition financial limitations necessitated budgeting that went beyond the scope of money management programs offered within the youth care environment. Moreover, inadequate income, as determined by ESIA policy, had serious repercussions that included food insecurity and homelessness. Shelter, utilities, transportation, personal needs and entertainment all competed with the food budget. Other policies such as those guiding the organization of food banks also played a role in the youths’ struggle to apply nutritional competency. Generally, the donor-reliant food bank system did not provide food items that the youth could use.

Mapping of Transitional Outcomes

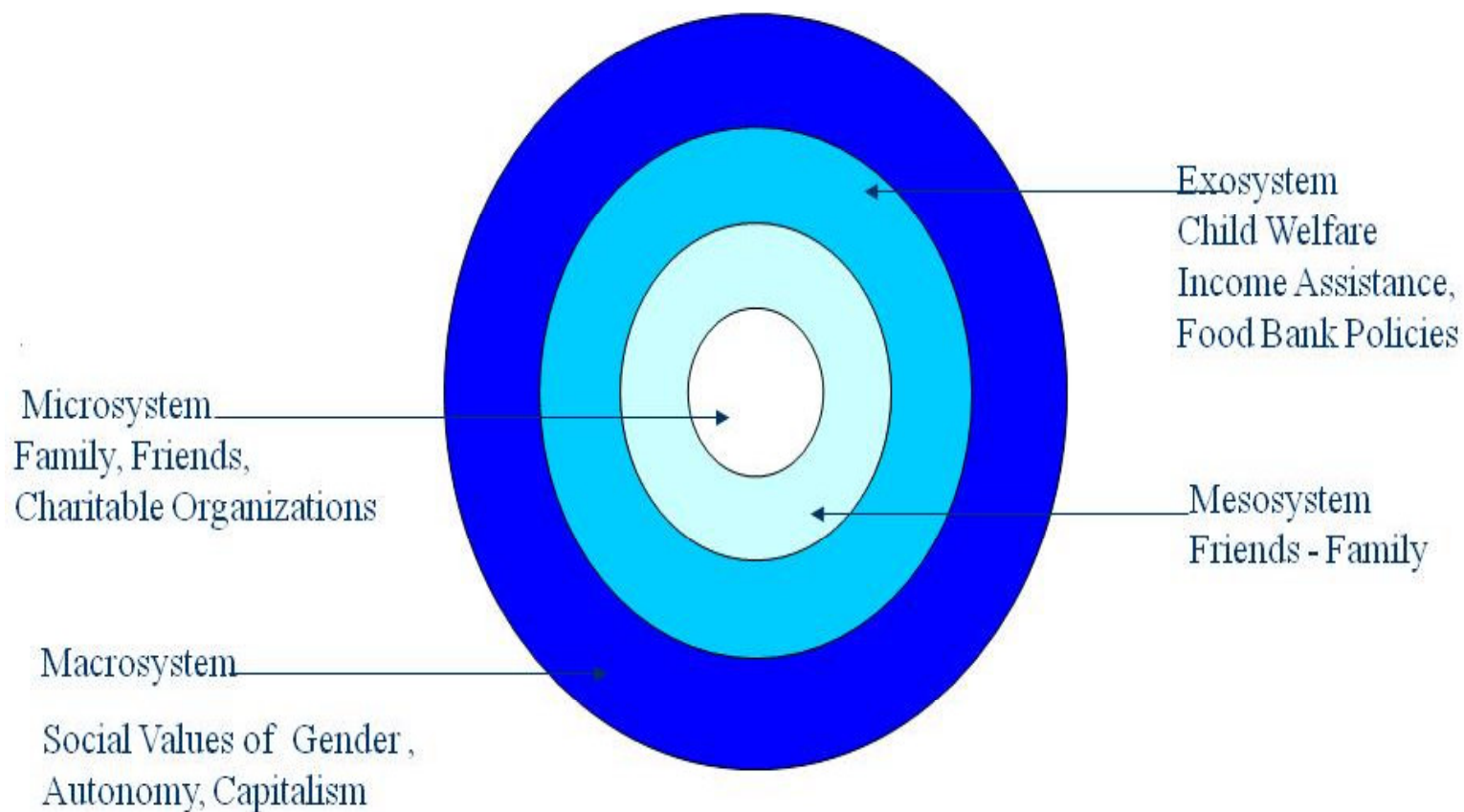

Figure 5: Transitional Outcomes Model

In part, the answer to improving transitional outcomes and nutritional competency lies in bridging the dichotomy of social relations that defined the custodial care and independence environments. (Figures 4 and 5) The evolution of youth care work to include family as part of therapeutic and daily life events represents one response to the addressing the challenges of transition. (27) This practice will help to expand the youth's microsystem relation beyond the walls of the youth care milieu and in turn contribute to the establishment of a post transition support system. The participants in this study all indicated that their family was a support. Some respondents stated that family relationships were rekindled or intensified after they left custodial care. This provides evidence of the significance of family or 'kin' involvement throughout the youths' custodial care experience. It is these 'significant others' that will provide a constant connection to lessen the brunt of isolation and loneliness that occurs post transition.

The expansion of Supervised Apartment Programs to act as transitional bridges between custodial care and independence would also help improve transitional outcomes. Within these environments, youth are given the opportunity to practice life skills through trial and error without the fear of losing their shelter. As one participant stated, *you learn nonetheless, you learn*. As such, it is not a question of whether the youth will gain nutritional competency and the complementary life skills necessary for its application; it is a matter of ensuring they have the financial, social and emotional support to follow them from custodial care to independence.

The abruptness of transition requires government intervention and political will to ensure that supports and adequate resources are in place prior to custodial care discharge and continue until the young person is able to gain a secure footing within the adult world. This study indicated that there are specific target areas to improve nutritional competency within the youth care milieu. However, until social policy makers recognize the extent of the transition challenges

of poverty and isolation, faced by youth in care, the capacity to apply nutritional competency will be compromised.

7.2 Limitations

There are several potential limitations to consider within this study.

The design of the study involved a narrow geographical area of interest and a small participant involvement

Three of the youth participants and two facility representatives of the study were known to me as a youth care worker, which, in turn, may have influenced their presentation and interview responses.

The process of recruitment was such that youth respondents were currently accessing post care services such as food banks; drop in centers and Phoenix Programs. Therefore, the results would be reflective of this particular group and not indicative of all former youth in care.

The interview preamble, which identified my experience as a youth care worker, may have influenced the participants' responses.

7.3 Recommendations for Future Research:

1. The aim of this study was to gain an understanding of transition from the youth care milieu to independence in terms of acquiring and utilizing nutritional competency life skills. As presented in this research, there are many social relations that impact nutritional competency however the scope of this study was limited to impacts within the youth care milieu and post transitional food experiences. Future study is needed to further the understanding of the social relations that impact youth as they transition from custodial care to independence.

2. Additional attention on the transitional process in terms of the deconstruction and reconstruction if microcosmic support systems would also contribute to the understanding of youth in care transitions.
3. Time was limited for this study; thereby future study not limited by time constraints could duplicate this study and expand the scope of participants to include key personal and organizational relations that impact the youths' nutritional competency such as charitable organizations, Child Welfare workers, Income Assistance workers and family.
4. Many of the young people involved in this study voiced having limited contact with their family while in custodial care yet once transition occurred family contact became more frequent. Based on this finding future research could further explore the nature of these relationship
5. Future research may wish to explore the feasibility of using computer technology as a forum to distribute information to transitioned youth.

7.4 Recommendations for Government

1. Increase the age defining a child in need of services from sixteen to nineteen
2. Provide funding for the development of a peer mentorship program to support youth in transition until age 21.
3. Provide funding for the creation of more supervised apartment programs to act as transitional bridges from custodial care to independence.
4. Increase social assistance rates to guarantee the provision of a nutritious food basket.
5. Provide additional funding and expertise in the development of transitional programs focused on the psycho-social functioning and needs of transitioning youth

6. Collaborate with youth care associations in the development of a life skills checklist that would act as a benchmark to guide the development and implementation of individualized life skill programs.
7. Provide funding for the immediate hiring of house managers within all youth care facilities to provide a normalcy of daily life experiences for youth in custodial care.

7.5 Recommendations for Academic Institutions:

1. Include a basic nutrition course and food safety training in the Child and Youth Care Worker curriculum
2. Increase the availability and duration of family studies courses offered in both junior and senior high schools
3. Recognize the extraordinary circumstance of youth in care and strive to meet their needs
4. Support the development of transitional schools for youth who struggle to meet the expectations of mainstream schools and thereby require a period of adjustment.
5. Create opportunities for youth to participate in the school or community food service activities in exchange for credit hours.
6. Create cooking clubs within the school as an extra-curricular activity.

7.6 Recommendation for Youth Care Organizations:

1. Youth care organizations may wish to develop a training module aimed at teaching food related skills and nutritional knowledge to youth care workers.
2. Collectively lobby the government agencies for funding to provide Safe Food Handling Course to those working in the congregate care settings.

3. Organizations may wish to collaborate in the creation of a life skills continuum with the aim to establish early learning of life skills.
4. Develop a youth care association collective to collaborate and strengthen their approach to improving transitional planning and outcomes for youth.
5. Partner with academic institutions, specifically nutrition and health disciplines to foster consultative relationships
6. Seek dietetic intern student placements to review approaches to teaching nutrition skills and menu planning
7. Create a recipe book with simple, affordable nutritious meals to give to youth leaving custodial care
8. Collectively create resource booklets on street survival and post transitional information
9. Hire recently transitioned youth to facilitate the development of life skills programs that will reflect the after care needs of former youth in care.
10. Create menus in accordance with Canada's Food Guide that address the youths' health needs and align with the socio-economic reality of transitioned youth.

7.7 Recommendations for Youth Care Workers

1. Youth care workers may wish to reflect on their youth care practice in terms of engaging youth and modeling behavior
2. Youth care workers could increase their awareness of the transitional outcomes by seeking feedback
3. Youth care workers could unite their voices and lobby for an increase in the age defining of a child in need of protection

4. Seek opportunities to develop working relationships with community resources and work to familiarize the youth with these supports
5. Become knowledgeable in the transitional realities of youth leaving custodial care

7.8 Recommendations for Transitioned Youth

1. Use print mediums such as The Voice to create awareness of the transitional challenges following discharge from Child Welfare Care
2. Seek opportunities to mentor youth on the cusp of transition.

REFERENCES

1. Children and Family Services Act. (1990). Available from: Nova Scotia Department of Community Services: <http://www.gov.ns.ca/legislature/legc//statutes/childfam.html>; Cited October 3, 2008.
2. Statistics Canada. Delayed transitions of young adults. Ottawa: The Daily, Statistics Canada; 2007 18 Sept. Available from: <http://www.statcan.ca/Daily/English/070918/d070918b.htm>; Cited September 29, 2008.
3. Tweddle A. Youth leaving care-How do they fare? Briefing paper prepared for the Modernizing Income Security for Working Age Adults (MISWAA) Project with recommendations from the Laidlaw Foundation. Toronto ON; 2005. Available from: http://www.torontoalliance.ca/tcsa_initiatives/income_security/pdf/MISWAAYouthLeavingCareReport.pdf; Cited September 29, 2008.
4. Farris-Manning, C, Zandstra, M. Children in care in Canada. Child Welfare of League of Canada. 2003. Available from: http://www.nationalchildrensalliance.com/nca/pubs/2003/Children_in_Care_March_2003.pdf. Cited October 3, 2008.
5. Canada's response to the UN questionnaire on violence against children. 2004 10 Sept. Available from: <http://www.unicef.ca/portal/Secure/Community/502/WCM/WHATWEDO/ChildProtection/assets/canada.pdf>; Cited September 15, 2008.
6. National Youth in Care Network. 2007. Available from: <http://www.youthincare.ca/people/youthincare.html>; Cited October 3, 2008.

7. Human Resources and Social Development Canada. Summary of child population, children in child welfare care and age of protection Canada 1999, compiled from Child and Family Services Statistical Report 1996-1997 to 1998-99. 2001. Available from:
<http://www.hrsdc.gc.ca/en/cs/sp/sdc/socpol/publications/statistics/2004-002599/page05.shtml>
Cited October 3, 2008.
8. Wertheimer R. Research brief prepared for child trends. Youth who “age out” of foster care: Troubled lives, troubling prospects. Washington; 2002.
9. McMillen J, Tucker J. The status of older adolescents at exit from out of home care. *Child Welfare* 1999; 78: 339-60.
10. Courtney M, Piliavin I, Grogan-Kaylor A., Nesmith A. Foster youth transitions to adulthood: A longitudinal view of youth leaving care. *Child Welfare* 2001; 80: 685-717.
11. Reilly T. Transition from care: Status and outcomes of youth who age out of foster care. *Child Welfare League of Am* 2003; 82: 727-46.
12. Collins M. Transition to adulthood for vulnerable youths: A review of research and implications for policy. *Soc Ser Rev* 2001; 75: 271-91.
13. Haber GM, Toro PA.. Homelessness among families, children and adolescents: An ecological-developmental perspective. *Clin Child Fam Psych Rev* 2004; 7: 123-64.
14. Courtney M, Dworsky A. Early outcomes for young adults transitioning from out-of-home care in the USA. *Child and Fam Soc Work* 2006; 11: 209-19.
15. Anglin J. Staffed Group Homes for Youth: Toward a Framework for Understanding. In: Kufeldt K, McKenzie B. editors. *Child welfare: connecting, research, policy and practice*. Waterloo: Wilfrid Laurier University Press; 2003 p 191-201.

16. The Manual of Standards Policies and Procedures for Children in Care and Custody of the Minister. 2000. Available from: Nova Scotia Department of Community Services: http://www.gov.ns.ca/coms/families/documents/Children_in_Care_Manual.html; Cited October 3, 2008.
17. Kufeldt, K. Graduates of Guardianship Care. In Outcomes in early adulthood. In Kufeldt K, McKenzie B. editors. Child welfare: connecting research, policy and practice. Waterloo: Wilfrid Laurier University Press; 2003 p 203-16.
18. Mech EV, Ludy-Dobson C Hulseman FS. Life-skills knowledge: A survey of foster adolescents in three placement settings. Child Youth Ser Rev 1994; 16: 181-200.
19. Reid C, Dudding P. Building a future together: Issues and outcomes for transition-aged youth. 2006. Available from: <http://www.cecw-cepb.ca/files/file/en/BuildingAFutureTogether.pdf>; Cited October 3, 2008.
20. Mech EV. Preparing foster youth for adulthood: A knowledge-building perspective. Child Youth Ser Rev 1994; 16: 141-5.
21. Smart M. Making more sense of transitions. 2007. Available from: <http://www.cyc-net.org/LZ/a-21-2.html>; Cited October 3, 2008.
22. Mech EV. Foster youths in transition: Research perspectives on preparation for independent living. Child Welfare 1994; 73: 603-10.
23. Mann-Feder V, White T. The transition to independent living: Preliminary findings from the experiences of youth in care. In: Kufeldt K, McKenzie B. editors. Child welfare: connecting research, policy and practice. Waterloo: Wilfrid Laurier University Press; 2003 p 217-27.
24. Winfield J. Notes on change, transformation and transition. The International Child and Youth Care Network. 2002. Available from: <http://www.cyc-net.org/cyc-online/cyc01-0602-winfield.html>; Cited October 3, 2008.

25. Mann-Feder V, Garfat T. Leaving residential placement: A guide to intervention. *Rel Child Youth Care Prac* 2006; 19: 66-71.
26. Mann-Feder V, White T. Investing in termination: intervening with youth in the transition to independent living. 2006. Available from:
www.cyc-net.org/cyc-online/cyc01-0606-mann-feder.html; Cited October 3, 2008.
27. Garfat T. Working with Families: Developing a Child and youth Care Approach. In: Garfat T, editor. *A child and youth care approach to working with families*. New York: Haworth Press, 2003.
28. Rutman D, Barlow A, Hubberstey C, Alusik D, Brown E. Supporting young people's transition from government care. 2001. Available from:
<http://www.cccw-cepb.ca/files/file/en/YouthLeavingCSge1Report.pdf>; Cited October 3, 2008.
29. Agriculture and Agri-food Canada. (2006) Canada's fourth progress report on food security. Available from:
http://www.agr.gc.ca/misb/fsec-seca/pdf/report-rapport_4_e.pdf ; Cited October 3, 2008.
30. Dietitians of Canada. Individual household and food insecurity in Canada: Position of Dietitians of Canada. *Can J Diet Prac Res* 2005; 43-6.
31. Dauchner N, Tarasuk V. Homeless "squeegee kids": Food insecurity and daily survival. *Soc Sci & Med* 2002; 54: 1039-49.
32. Freundlich M, Avery RJ. Transitioning from congregate care: Preparations and outcomes. *J Child and Fam Stud* 2006; 15:507-18.
33. Kushel MB, Yen IH, Gee L, Courtney ME. Homelessness and health care access after emancipation. *Arch Ped Adolesc Med* 2007; 161: 986-93.

34. Burt M, Aran L, Douglas T, Valente J, Lee E, Iwen B. Homelessness: programs and the people they serve: findings of the National Homeless Assistance Providers and Clients. 1999. Available from: <http://www.urban.org/url.cfm?ID=310291>; Cited October 3, 2008.
35. Leslie B, Hare F. At Care's End: Child Welfare Grads and Street Youth Services. In: Kufeldt K, McKenzie B. editors. Child welfare: connecting research, policy and practice. Waterloo: Wilfrid Laurier University Press; 2003 p 239-47.
36. Tarasuk VS, Dachner N, Li J. Homeless youth in Toronto are nutritionally vulnerable. *J Nutr* 2005; 135: 1926-33.
37. Modlin, H. The Development of a Parent Support Group as a Means of Initiating Family Involvement in a Residential Program. In Garfat, T, editor. A child and youth care approach to working with families. New York: Haworth Press; 2003 p. 169-189.
38. Lemon K, Hines A, Merdinger J. From foster care to young adulthood: the role of independent living programs in supporting successful transitions. *Child Youth Ser Rev* 2005; 27: 251-70.
39. Mallon GP. After care, then where? Outcomes of an independent living program. *Child Welfare* 1998; 77: 61-78.
40. Scannapieco M, Schagrín J, Scannapieco T. Independent living programs: do they make a difference? *Child Adolesc Soc Work J* 1995; 12: 381-9.
41. Youth in Care Network. Mini poll 2008. [cited 2008 1 Oct]. Available from: <http://www.youthincare.ca/link/welfare.html>.
42. Health Canada. Canadian Community Health Survey Cycle 2.2. Income-related Household Food Security in Canada. Office of Nutrition Policy and Promotion. Ottawa: Ministry of Health Canada; 2004 [cited 2008 3 Oct]. Available from: http://www.hc-sc.gc.ca/fn-an/surveill/nutrition/commun/income_food_sec-sec_alim-eng.php

43. Urban Poverty Project. Ottawa: Canadian Council on Social Development; 2007 [cited 2008 3 Oct] Available from: Ministry of Human Resources and Social Development: <http://www.ccsd.ca/pubs/2007/upp/index.htm>.
44. Vozoris NT, Davis B, Tarasuk VS. The affordability of a nutritious diet for households on welfare in Toronto. *Can J Public Health*, 2002; 93: 36- 40.
45. National Council of Welfare. *Welfare Incomes 2005*. Ottawa: Minister of Public Works and Government Services Canada; 2006.
46. Riches G. *First world hunger: food security and welfare politics*. New York: St Martin's Press Inc; 1997.
47. Nova Scotia Participatory Food Security Projects. *Cost and affordability of a nutritious diet in Nova Scotia report of 2007 food costing*. 2008
48. Williams PL, Johnson CP, Kratzmann ML, Johnson CS, Anderson BJ, Chenall C. Can households earning minimum wage in Nova Scotia afford a nutritious diet? *Can J Public Health* 2006; 97(6): 430-4.
49. McIntyre L, Glanville NT, Officer S, Anderson B, Raine KD, Dayle JB. Food insecurity of low-income mothers and their children in Atlantic Canada. *Can J Public Health* 2002; 93:411-5.
50. Travers KD. The social organization of nutritional inequalities. *Soc Sci and Med* 1996; 43 (4): 543-53.
51. Travers KD. Nutrition education for social change: critical perspective. *J Nutr Ed* 1997; 29: 57-62.
52. Tarasuk, V. Household food insecurity with hunger is associated with women's food intakes, health and household circumstance. *J Nutr* 2001; 131 (10): 2670-6.

53. Tarasuk V, Beaton G. Household food insecurity and hunger among families using food banks. *Can J Public Health* 1999; 90: 109-13.
54. Shank G. *Qualitative research: a personal skills approach*, 2nd ed. Upper Saddle River: Pearson Education Inc, 2006.
55. Patton MQ. *Qualitative research and evaluation methods* 3rd ed. Thousand Oaks: Sage Publications, 2002.
56. Bronfenbrenner U. *The ecology of human development: experiments by nature and design*, Cambridge, MA: Harvard University Press, 1979.
57. Paquette D, Ryan J. Bronfenbrenner's ecological systems theory. National Louis University. 2000. Available from: <http://pt3.nl.edu/paquetteryanwebquest.pdf>; Cited October 3, 2008.
58. Huberman AM, Miles MB. *The qualitative researcher's companion*. Thousand Oaks: Sage Publications, 2002.
59. Lincoln YS, Guba EG. *Naturalistic inquiry*. Beverly Hills: Sage Publications, 1985.
60. Au KH, Kawakami AJ. Culture and ownership: schooling of minority students. *Child Ed* 1991; 67: 280-4.
61. Garfat T. *Developmental stages of child and youth workers*; 2001. Available from: www.cyc-net.org/cyc-online/cycol-0101-garfat.html. Cited October 3 2008.
62. Hesse-Biber SN, Leavy P. *Approaches to qualitative research: A reader on theory and practice*. New York: Oxford University Press, 2004.
63. Guba EG, Lincoln YS. *Paradigmatic Controversies, Contradictions and Emerging Confluences*. In Denzin NK, Lincoln YS, editors. *The sage handbook of qualitative research* 3rd ed. Thousand Oaks: Sage Publications; 2005.
64. Patton MQ. *Qualitative evaluation and research methods*, 2nd ed. Newbury Park: Sage Publications, 1990.

65. Erlandson DA, Harris EL, Skipper BL, Allen SD. Doing naturalistic inquiry: a guide to methods. Newbury Park: Sage Publications, 1993.
66. Bickel G, Nord M, Price C, et al. Guide to measuring household food insecurity Revised 2000. Alexandria, VA: United States Department of Agriculture, Food and Nutrition Service, Office of Analysis, Nutrition and Evaluation: 2000. Available from: <http://www.fns.usda.gov/fsec/FILES/FSGuide.pdf>; Cited October 3, 2008.
67. Vozoris NT, Tarasuk VS. Household food insufficiency is associated with poorer health. *J Nurt* 2003; 133: 120-6
68. Jacobs Starkey L, Kuhnlein HV, Gray-Donald K. Food bank users: sociodemographic and nutritional characteristics. *CMAJ*. 1998; 158: 1143-9.
69. Employment Support and Income Assistance Policy Manual. 2008. Available from: Nova Scotia Department of Community Services: Available from: http://www.gov.ns.ca/coms/employment/income_assistance/ESIAManual.htm; Cited August 30, 2008
70. Teron AC, Tarasuk VS. Charitable food assistance: what are food bank users receiving? *Can J Public Health* 1999; 90: 382-4.

Appendix A
Recruitment Poster for Youth Participants

Have you been “in care”? Lived in a group home? Do you now live on your own?

Research study seeks to learn more about the food experiences of former ‘Youth in Care’ Who now live or have lived on their own.



You will be asked to take part in an interview (about 1 hour) and you will be compensated for your time.

Please contact Valerie Blair () if you want to take part or learn more about the study. Thank you!

Appendix B
Letter to Youth Participants

Valerie Blair
4 Beldina Drive
Dartmouth, Nova Scotia
B3A-4L1

Dear Youth:

My name is Valerie Blair and I have worked as a youth care worker for thirteen years. I am a graduate student in the Department of Applied Human Nutrition at Mount Saint Vincent University. As part of the program, I am doing research study about life skills programs and the food experiences of former 'youth in care' now living on their own.

The goal of this study is to learn more about the process of moving from a group home/youth care facility to your own apartment. Many youth care facilities will have life skills programs to help your move to independence. This study is interested in how these programs helped you gain nutritional knowledge, skills or awareness.

As part of the study, I would like to learn more about your food experiences since living on your own. Food insecurity means that a person is not sure that they will have healthy, affordable food every day. This study wishes to see if life skills programs and social policies have met your needs as you experienced leaving the child welfare system.

I am looking for former 'youth in care' to participate in a one-on-one interview that will be voice recorded and will last about 1 to 1½ hours. If you agree to be part of the study, we will set up a time and place that meets your needs. Your involvement is voluntary and you may withdraw from the study at any time. Your choice to leave the study will not have any negative consequences; your ability to be part of any programs and services will not be affected because you choose to be (or not to be) part of this study. If any part of the interview causes you stress or discomfort, counseling services will be available if you feel that there are issues you wish to talk about some more.

After the interview is completed, the voice recording will be copied onto paper. You will have the option to read this paper and decide if the responses you gave were correct or correctly interpreted.

If you agree to participate, your identity will be completely protected and the information you share will only be used for this study. There is a possibility that confidentiality cannot be guaranteed because the researcher is required to report abuse or self-harm. For your participation, you will receive a small financial gift of twenty dollars per hour for your time and effort. Transportation to and from the interview will be available.

This research will have the approval of the Department of Applied Human Nutrition and the University Ethics Committee.

You may contact me at (██████████), any time if you have questions or concerns. You may also contact my thesis advisor, Dr Theresa Glanville at:

Dr. Theresa Glanville
Department of Applied Human Nutrition
Mount Saint Vincent University
Telephone: 457-6248
Email: Theresa.Glanville@msvu.ca

or Chair, University Ethics Research Board
MSVU Research and International Office
Telephone: 457-6337
Email: research@msvu.ca

Once again, I will be in contact regarding a time and place for the interview.

Thank you for your time and I look forward to learning from you.

Respectfully,

Valerie Blair
MscAHN student
Dept. Applied Human Nutrition

Dr Theresa Glanville
Thesis Advisor
Dept. Applied Human Nutrition
Mount Saint Vincent University

Appendix C
Letter to Youth Care Facility Participants

Valerie Blair
4 Beldina Drive
Dartmouth, Nova Scotia
B3A-4L1

Dear Staff Member

Please allow me to introduce myself. My name is Valerie Blair, a graduate student in the Department of Applied Human Nutrition at Mount Saint Vincent University. Currently, I am undertaking supervised research entitled “Meals at The Home; Meals All Alone; Nutritional Competency and Food Security Relative to Transition from a Residential Youth Care Facility to Independence.” I have worked for thirteen years as a youth care worker and in this capacity developed a keen awareness of life skills programs and their significance in transitional planning.

The proposed research will seek to further the understanding of transition from child welfare care vis-à-vis a general exploration of life skills programming with a specific focus on food related skills, knowledge and awareness, herein referred to as nutritional competency. As such, the study aims to gain an understanding of becoming nutritionally competent within the youth care facility milieu and the usefulness of the competencies once independence is achieved. Another focus of the study is to explore the effects of transition on food security and identify the social processes that contribute to this issue. Many social programs and policies play a role in a young person’s nutritional competence and food security. Life skills programming offered at community-based youth care facilities are just one part of the puzzle.

Learning about your facility’s life skills program and the philosophical, economic, social, cultural and gender influences that guides its development and delivery is a vital part of this research. As such, I am seeking volunteers to participate in a voice recorded one-on-one interview, estimated to take 1 to 1½ hours. Once the interview is completed, the voice recording will be transcribed. You will have an opportunity to review this document to ensure that the interview responses are accurate and reflective of the intended meaning

Participation is voluntary and you may withdraw from the study at any time without consequence. If you agree to participate, you can contact me and we can determine a place, date and time for the interview.

If you agree to participate, the identity of both respondent and facility he/she represents will be kept confidential. The information you share will be used solely for the purposes of this particular study. I recognize that your time is valuable and would greatly appreciate your contribution.

Before beginning, this research will have the approval of the Department of Applied Human Nutrition and the University Ethics Committee.

You may contact me by telephone at [REDACTED] or by email at [REDACTED] at any time if you have any questions or concerns.

You may also contact my thesis advisor, Dr Theresa Glanville at:

Dr. Theresa Glanville
Department of Applied Human Nutrition
Mount Saint Vincent University
Telephone: 457-6248
Email: Theresa.Glanville@msvu.ca

or Chair, University Ethics Research Board
MSVU Research and International Office
Telephone: 457-6350
Email: research@msvu.ca

Thank you for your time and I look forward to learning from you.

Respectfully,

Valerie Blair
MscAHN student
Dept. Applied Human Nutrition

Dr Theresa Glanville
Thesis Advisor
Dept. Applied Human Nutrition
Mount Saint Vincent University

Appendix D
Interview Script for Youth Participants

Addendum D Interview Script for Transitioned Youth

Duration: Estimate 1-1 ½ hours

Location: To be determined with participant

Introduction:

First, thank you for your participation in this interview. The goal of this study is to know more about the process of moving from a group home (care facility) to your own apartment and the impact this event has on your food related skills, knowledge, awareness and food security experiences. Food security means that a person is not sure that they will have healthy, affordable food every day. The project wishes to see if life skills programs and social policies have met your needs as you experienced leaving the child welfare system. Through this study, I hope to identify some of the barriers that exist and make some suggestions on how programs can do better in terms of preparing young people for independence. I will also be going to five youth care associations within the HRM to ask about their independent programs as they relate to food related skills, knowledge and awareness.

Your transition experiences and how that impacted your food skills, knowledge, awareness and experiences is important to this research. There are no right or wrong answers.

The consent form we reviewed stated that the interviews would be tape-recorded. If this makes you uncomfortable, please let me know and it can be turned off. This interview will be kept confidential and there will be no identifying information used in the write up of the study.

There is no set time limit but it is thought it will take between 1 and 1 ½ hours. If you need a break at any time please let me know. If you have any questions please feel free to ask them at any time during or after the interview

Are there any questions before I begin? May we start now?

Demographics:

Gender: F or M

Age:

Age at Time of Discharge:

How many placements did you experience while in care?

Education Level:

Sources of Income:

Interview Questions:

How long were you in care prior to moving out on your own?

Can you tell me about your experiences with living independently?

How would you describe your level of readiness?

What supports or information did you find helpful when you were planning to move out on your own?

Did the youth care facility offer any life skills program? If so, can you describe the program?

Can you describe any food related skills, for example, cooking, budgeting or following a recipe you learned or experienced while in care?

Can you describe any food related knowledge, for example, healthy foods or following Eating Well With Canada's Food Guide, you learned or experienced while in care?

Can you describe any food related awareness, for example, available food resources, accessing nutrition information, you learned or experienced while in care?

Were you able to apply your skills, knowledge and awareness to your current situation (independent setting)?

If there were no programs, how did you think you learned food related skills, food knowledge and food awareness?

What have you discovered most challenging about living on your own, in terms of food and nutrition related topics?

What strategies do you use to meet your nutritional needs?

Do you use any of these methods to get food?

- Food banks
- Resource centers
- Community gardens
- Family
- Friends
- Youth Care Facility

Thinking of nutrition and food related themes:

If you were to advise youth who are moving out on their own, what would you tell them?

What suggestions could you offer to youth care facilities that would improve their approach to preparing youth for independence?

Appendix E
Interview Script for Youth Care Facility Representatives

Addendum E Interview Script for Residential Youth Care Facilities

Duration: Estimate 1 hour

Location: To be determined by the facility

Introduction:

Thank you for agreeing to be part of this research project. The purpose of the study is to gain an understanding of the process of becoming nutritionally competent within the youth care facility milieu and the usefulness of the competencies once independence is achieved. Nutritional competencies include food related skills, knowledge and awareness. The study will also explore the effects of transition on food security and identify the social processes that contribute to this issue. Many social programs and policies play a role in a young person's nutritional competence and food security. Life skills programming offered at community-based youth care facilities are just one part of the puzzle.

Hearing about your life skills programs is a vital part of this research. There is no right or wrong approach to describing the facility's life skills program. I ask that you be as detailed as possible, in terms of relating the program to the philosophical, economic, social, cultural and gender influences that guide its development and delivery. Please note that you may decline from answering any question or part thereof or stop the interview at any time.

As indicated in the consent form, I will be using a voice recorder to document this interview. If this poses a problem at any time, please let me know. There is no set time for the interview however, it is estimated to take one hour. If you need to stop at any time, please let me know. Questions can be posed at any time throughout the interview.

Facility Information:

Gender of youth served: Co-Ed _____ Female _____ Male _____

Ages of youth served: _____

Average length of stay: _____

Interview Questions:

Please tell me about your program.

Overall how would describe the process of youth transitions to independence?

Do you believe that the youth are adequately prepared for independence? Please explain.

Are there areas that stand out as needing more attention?

Are there areas that stand out as needing less attention?

Please describe the life skills program offered at _____(*facility name*).

Can you now focus on the nutritional competency (food related skills, knowledge and awareness) component of the life skills or independent training program offered at your facility, using as much detail as possible.

If there is no specific nutritional component to the life skills program, how do you think the youth learn nutritional competence?

What resources are you aware of that the youth could access?

Can you identify and elaborate on the strengths of the life skills program in general and specifically on the food related aspects the program?

Can you identify and elaborate on the barriers that impact the life skills program and food related aspects?

How do think the youth fare in terms of nutritional competency and food security once on their own?

In your experience, do the youth seek out food related support from youth care workers once they move out? For example, will the former youth residents make phone calls for recipes, cooking guidance, advice on accessing food or money?

What strategies do you think would further develop the nutritional competency module of your life skills program?

What suggestions do you have for improving the transitional outcomes of former youth in care?

Appendix F
Household Food Security Survey Module

Canadian Community Health Survey: Household Food Security Survey Module¹

The following questions are about the food situation for your household in the past 12 months.

Q1.²⁰ Which of the following statements best describes the food eaten in your household in the past 12 months, that is since [current month] of last year?

1. You and other household members always had enough of the kinds of foods you wanted to eat.
2. You and other household members had enough to eat, but not always the kinds of food you wanted.
3. Sometimes you and other household members did not have enough to eat.
4. Often you and other household members didn't have enough to eat.

Don't know / refuse to answer (Go to end of module)

The HFSSM begins here:

Now I'm going to read you several statements that may be used to describe the food situation for a household. Please tell me if the statement was often true, sometimes true, or never true for you and other household members in the past 12 months.

Q2. The first statement is: you and other household members worried that food would run out before you got money to buy more. Was that often true, sometimes true, or never true in the past 12 months?

1. Often true
2. Sometimes true
3. Never true

Don't know / refuse to answer

Q3. The food that you and other household members bought just didn't last, and there wasn't any money to get more. Was that often true, sometimes true, or never true in the past 12 months?

1. Often true
2. Sometimes true
3. Never true

Don't know / refuse to answer

Q4. You and other household members couldn't afford to eat balanced meals. In the past 12 months was that often true, sometimes true, or never true?

1. Often true
2. Sometimes true
3. Never true

Don't know / refuse to answer

IF CHILDREN UNDER 18 IN HOUSEHOLD, ASK Q5 AND Q6; OTHERWISE, SKIP TO FIRST LEVEL SCREEN

Now I'm going to read a few statements that may describe the food situation for households with children.

Q5. You or other adults in your household relied on only a few kinds of low-cost food to feed the child(ren) because you were running out of money to buy food. Was that often true, sometimes true, or never true in the past 12 months?

1. Often true
2. Sometimes true
3. Never true

Don't know / refuse to answer

Q6. You or other adults in your household couldn't feed the child(ren) a balanced meal, because you couldn't afford it. Was that often true, sometimes true, or never true in the past 12 months?

1. Often true
2. Sometimes true
3. Never true

Don't know / refuse to answer

FIRST LEVEL SCREEN (screener for Stage 2): If AFFIRMATIVE RESPONSE to ANY ONE of Q2-Q6 (i.e., "often true" or "sometimes true") OR response [3] or [4] to Q1, then continue to STAGE 2; otherwise, skip to end.



STAGE 2: Questions 7-11 - ask households passing the First Level Screen

IF CHILDREN UNDER 18 IN HOUSEHOLD, ASK Q7; OTHERWISE SKIP TO Q8

Q7. The child(ren) were not eating enough because you and other adult members of the household just couldn't afford enough food. Was that often, sometimes or never true in the past 12 months?

1. Often true
2. Sometimes true
3. Never true

Don't know / refuse to answer

The following few questions are about the food situation in the past 12 months for you or any other adults in your household.

Q8. In the past 12 months, since last [current month] did you or other adults in your household ever cut the size of your meals or skip meals because there wasn't enough money for food?

1. Yes
2. No (Go to Q9)

Don't know / refuse to answer

Q8b. How often did this happen?

1. Almost every month
2. Some months but not every month
3. Only 1 or 2 months

Don't know / refuse to answer

Q9. In the past 12 months, did you (personally) ever eat less than you felt you should because there wasn't enough money to buy food?

1. Yes
2. No

Don't know / refuse to answer

Q10. In the past 12 months, were you (personally) ever hungry but didn't eat because you couldn't afford enough food?

1. Yes
2. No

Don't know / refuse to answer

Q11. In the past 12 months, did you (personally) lose weight because you didn't have enough money for food?

1. Yes
2. No

Don't know / refuse to answer



SECOND LEVEL SCREEN (screener for Stage 3): If AFFIRMATIVE RESPONSE to ANY ONE of Q7-Q11, then continue to STAGE 3; otherwise, skip to end.

STAGE 3: Questions 12-16 - ask households passing the Second Level Screen

Q12. In the past 12 months, did you or other adults in your household ever not eat for a whole day because there wasn't enough money for food?

1. Yes
2. No (IF CHILDREN UNDER 18 IN HOUSEHOLD, ASK Q13; OTHERWISE SKIP TO END)

Don't know / refuse to answer

Q12b. How often did this happen?

1. Almost every month
2. Some months but not every month
3. Only 1 or 2 months

Don't know / refuse to answer

IF CHILDREN UNDER 18 IN HOUSEHOLD, ASK Q13-16; OTHERWISE SKIP TO END

Now, a few questions on the food experiences for children in your household.

Q13. In the past 12 months, did you or other adults in your household ever cut the size of any of the children's meals because there wasn't enough money for food?

1. Yes
2. No

Don't know / refuse to answer

Q14. In the past 12 months, did any of the children ever skip meals because there wasn't enough money for food?

1. Yes
2. No

Don't know / refuse to answer

Q14b. How often did this happen?

1. Almost every month
2. Some months but not every month
3. Only 1 or 2 months

Don't know / refuse to answer

Q15. In the past 12 months, were any of the children ever hungry but you just couldn't afford more food?

1. Yes
2. No

Don't know / refuse to answer

Q16. In the past 12 months, did any of the children ever not eat for a whole day because there wasn't enough money for food?

1. Yes
2. No

Don't know / refuse to answer

End of module

²⁰ Question Q1 is not used directly in determining household food security status.

1 Health Canada (2007). Canadian Community Health Survey Cycle 2.2, Nutrition (2004). *Income-Related Household Food Security in Canada*. (available at: www.hc-sc.gc.ca/fn-an/surveill/nutrition/commun/income_food_sec_sec_alim_e.html#appa).

Appendix G
Free and Informed Consent for Youth Participants



Excellence • Innovation • Discovery
Department of Applied Human Nutrition

Free and Informed Consent Form

Meals at The Home; Meals All Alone: Nutritional Competency and Food Security Relative to Transition from a Residential Youth Care Facility to Independence/ Valerie Blair

I am a graduate student in the Department of Applied Human Nutrition at Mount Saint Vincent University. As part of my Master of Science in Applied Human Nutrition, I am doing a research project with Dr. Theresa Glanville, as my supervisor. I am inviting you to take part in my study, “Meals at The Home; Meals All Alone: Nutritional Competency and Food Security Relative to Transition from a Residential Youth Care Facility to Independence.” The purpose of this research is to get a better understanding of moving from a youth care facility to your own place as it applies to food related skills, knowledge, awareness, and food security. It is hoped that this study will help improve the quality of nutrition related life skills training offered at the youth care facilities throughout the Halifax Regional Municipality.

This study will involve a voice recorded, interview that will be about 1 to 1½ hours. After the interview is completed, the voice recording will be copied onto paper. You will have the option to read this paper and decide if the responses you gave were correct or correctly interpreted. In addition to the interview, The Measurement of Household Food Security Module (Canadian Community Health Survey, 2004) will be completed to learn about your experience with food insecurity. A few youth care facilities in the Halifax Regional Municipality will be interviewed to learn more about the life skills programs that they offer to ‘youth in care’. The study will be finished by July 2008. At the end of the study, a copy of the thesis will be available so you can see the results. Once it is finished, it is hoped that there will be some suggestions that may improve life skills programs offered at the residential group homes.

The benefit in participating in this research is the chance to help others understand what it is like to move from a group home environment to independence, by sharing your story, the challenges and successes. It is believed that there will be no harm or risk to you for being part of this study. You will be asked questions about your experiences while in the child welfare system and the group home environment. You do not have to answer any question you do not feel comfortable with or wish to share. Your participation is voluntary and your ability to be part of any programs and services will not be affected because you choose to be (or not to be) part of this study. You may withdraw from this study at any time without penalty. If any part of the interview causes you stress or discomfort, counseling services will be available if you feel that there are issues you wish to talk about some more.

If you agree to be part of this study, your identity and any information you share will be kept confidential and used for this research study only. There is a possibility that confidentiality cannot be guaranteed because the researcher is required to report abuse or self-harm.

Once the voice recordings are transcribed to paper, the tapes will be destroyed. When not in use, all the written material connected to this study will be locked in a cabinet at Mount Saint Vincent University; only the researcher and the research advisor will be able to access the material. Once the study is finished, all the papers will be shredded. It is likely that direct quotes will be used in the final thesis; care will be taken to make sure that name or any other information that would identify the person will not be included in the thesis. No one will be identified without permission.

If you have any questions about this study, please contact Valerie Blair, by telephone at [REDACTED] or by e-mail at [REDACTED] or Dr. Glanville, by telephone at 457-6248 or by e-mail at Theresa.Glanville@msvu.ca. This research study has met the ethical standards of the University Research Ethics Board at Mount Saint Vincent University. If you have any questions or concerns about this study and wish to speak with someone who is not directly involved with this study, you may contact the University research Ethics Board, by phone at 902-457-6350 or by e-mail at research@msvu.ca.

By signing this consent form, you are indicating that you fully understand the above information and agree to participate in this study.

Participant's signature

Date

Researcher's signature

Date

One signed copy to be kept by the researcher, one signed copy to the participant_____

Appendix H
Free and Informed Consent for Youth Care Facility Representatives



Excellence • Innovation • Discovery
Department of Applied Human Nutrition

Free and Informed Consent Form

Meals at The Home; Meals All Alone: Nutritional Competency and Food Security Relative to Transition from a Residential Youth Care Facility to Independence/ Valerie Blair

I am a graduate student in the Department of Applied Human Nutrition at Mount Saint Vincent University. As part of my Master of Science in Applied Human Nutrition, I am doing a research project with Dr. Theresa Glanville, as my supervisor. I am inviting you to take part in my study, “Meals at The Home; Meals All Alone: Nutritional Competency and Food Security Relative to Transition from a Residential Youth Care Facility to Independence.” The purpose of this research is to get a better understanding of moving from a youth care facility to your own place as it applies to food related skills, knowledge, awareness, and food security. It is hoped that this study will help improve the quality of nutrition related life skills training offered at the youth care facilities throughout the Halifax Regional Municipality.

This study will involve a voice recorded, interview that will be about 1 to 1½ hours. After the interview is completed, the voice recording will be copied onto paper. You will have the option to read this paper and decide if the responses you gave were correct or correctly interpreted. In addition to the interview, The Measurement of Household Food Security Module (Canadian Community Health Survey, 2004) will be completed to learn about your experience with food insecurity. A few youth care facilities in the Halifax Regional Municipality will be interviewed to learn more about the life skills programs that they offer to ‘youth in care’. The study will be finished by July 2008. At the end of the study, a copy of the thesis will be available so you can see the results. Once it is finished, it is hoped that there will be some suggestions that may improve life skills programs offered at the residential group homes.

The benefit in participating in this research is the chance to help others understand what it is like to move from a group home environment to independence, by sharing your story, the challenges and successes. It is believed that there will be no harm or risk to you for being part of this study. You will be asked questions about your experiences while in the child welfare system and the group home environment. You do not have to answer any question you do not feel comfortable with or wish to share. Your participation is voluntary and your ability to be part of any programs and services will not be affected because you choose to be (or not to be) part of this study. You may withdraw from this study at any time without penalty. If any part of the interview causes you stress or discomfort, counseling services will be available if you feel that there are issues you wish to talk about some more.

If you agree to be part of this study, your identity and any information you share will be kept confidential and used for this research study only. There is a possibility that confidentiality cannot be guaranteed because the researcher is required to report abuse or self-harm.

Once the voice recordings are transcribed to paper, the tapes will be destroyed. When not in use, all the written material connected to this study will be locked in a cabinet at Mount Saint Vincent University; only the researcher and the research advisor will be able to access the material. Once the study is finished, all the papers will be shredded. It is likely that direct quotes will be used in the final thesis; care will be taken to make sure that name or any other information that would identify the person will not be included in the thesis. No one will be identified without permission.

If you have any questions about this study, please contact Valerie Blair, by telephone at [REDACTED] or by e-mail at [REDACTED] or Dr. Glanville, by telephone at 457-6248 or by e-mail at Theresa.Glanville@msvu.ca. This research study has met the ethical standards of the University Research Ethics Board at Mount Saint Vincent University. If you have any questions or concerns about this study and wish to speak with someone who is not directly involved with this study, you may contact the University research Ethics Board, by phone at 902-457-6350 or by e-mail at research@msvu.ca.

By signing this consent form, you are indicating that you fully understand the above information and agree to participate in this study.

Participant's signature

Date

Researcher's signature

Date

One signed copy to be kept by the researcher, one signed copy to the participant_____

Appendix I
Consent to Voice Recording



Excellence • Innovation • Discovery

Department of Applied Human Nutrition

I, _____ agree to allow the use of voice recording equipment

(Please Print)

during an in-depth interview, as part of the research study entitled, **Meals at The Home; Meals All Alone: Nutritional Competency and Food Security Relative to Transition from a Residential Youth Care Facility to Independence.**

I understand that once the voice recordings are transcribed the tapes will be destroyed.

Signature: _____

Date: _____

Table 1
Demographic Profile of Youth Participants

Table 4.1: Characteristic Profile of Youth Participants

Youth	1	2	3	4	5	6	7
Age	26	26	20	19	21	21	23
Age at Discharge	18	18	19	17	18	20	20
# Placements	36	2	10	15	4	6	5
Education	10	8	12	9	9	College	10
Income Source	ESIA	ESIA	ESIA	Work	ESIA	ESIA	Work
Time Out of Home	7 years	9 months	8 years	4 years	5 years	4 years	3 years

Table 2
Demographic Profile of Youth Care Facilities

Table 4.2 Characteristic Profiles of Participating Youth Care Facilities

Facility	1	2	3	4	5
Gender	Male	Co-ed	Male	Female	Female
Age (years)	14-18	12-16	16-19	12-18	15-21
Average Length of Stay (months)	9-10	N/K*	10-12	6-9	8-12

- This information was overlooked during the interview

Table 3
Sample of Coding

Table 3: Coding Sample

Responses

	Second Level	Third Level	Category
Structured			
Doing it for you			
Bribe you	Approach Influence		
Not learning nothing	Positive and Negative		
All fun			
Treatment plans			
Care plan meetings		In Care Experiences	
Cook for the house		& Perceptions	
Keeping things clean			
Basic skills	Environmental Influence		
No junk food			
Healthy			
Nutritional meals			
Always food in the cupboard			
Rough time			
Didn't care			
Did my own thing	Negative Personal influence		
Prove to myself			Transitional Life
Didn't really listen			Skill Influences
Waste of time			Youth & Staff
Forced			Experience & Perspective
Not cooks	Negative staff influences		
Disinterested	(Internal YCF)		
Standards		Negative Influences to	
Single staffed	Negative organizational	Nutritional Competence	
Regulations	influences		
Feel independent			
Fear			
Anger	Emotional influences		
Doubt			
Trail and error			
Interaction			
More hands on			
In the moment	Approaches to learning		
Self-taught	nutritional competence		
Jokes and games			
Watch how to do it			
Asked			
Source of information		Positive Influences to	
Job to do		Nutritional competence	
Give advice			
Talk to	Positive staff role/influences		
Model behavior	(Internal YCF)		
Teach			
Spend time			
Show respect			
Learned in school			
Cooking classes	Community Influences		
Grocery tours	(External YCF)		
Money			

